

Energy Supply Systems

SINGLE POLE INSULATED CONDUCTOR RAIL



811

10 -100 amps

wampfler
solutions for a moving world

TABLE OF CONTENTS

	Page		Page
DESCRIPTION	1	SPARE PARTS	28
REGULATIONS	2	Collector Shoes	28
TECHNICAL DATA PROGRAMME 811	3	Stabilizing Spring	28
SELECTION	3	ACCESSORIES	29
TECHNICAL EXPLANATION	4- 5	TOOLS	30-31
PARTS OF THE		CURVES	32
CONDUCTOR RAIL SYSTEM	6-27	QUESTIONNAIRE	33-34
Insulated Conductor Rails	6	SYSTEM ARRANGEMENT	35
Rail Connector	7	SLIP RING ASSEMBLY	36
Expansion Joint	7- 8	COMPACT SYSTEM	37
Power Feeds	9	APPLICATION EXAMPLES	38-41
Power Feed Clamp	10	PROGRAMME 811 IN USE	42-45
Power Feed Clip	10	ADDITIONS TO THE	
Isolating Joint	11	wamplifier-CONDUCTOR RAIL SYSTEMS	46-48
Isolating Piece	11		
Air Gap Isolating Section	11		
Anchor Clamps	12		
End Caps	12-17		
Hanger Clamps	18-19		
Pick-up Guides	20-21		
Current Collectors	22-24		
Connection Cables	22-24		
Towing Arm	24		
Collector Support Bracket	24		
Current Collector Units	25-27		

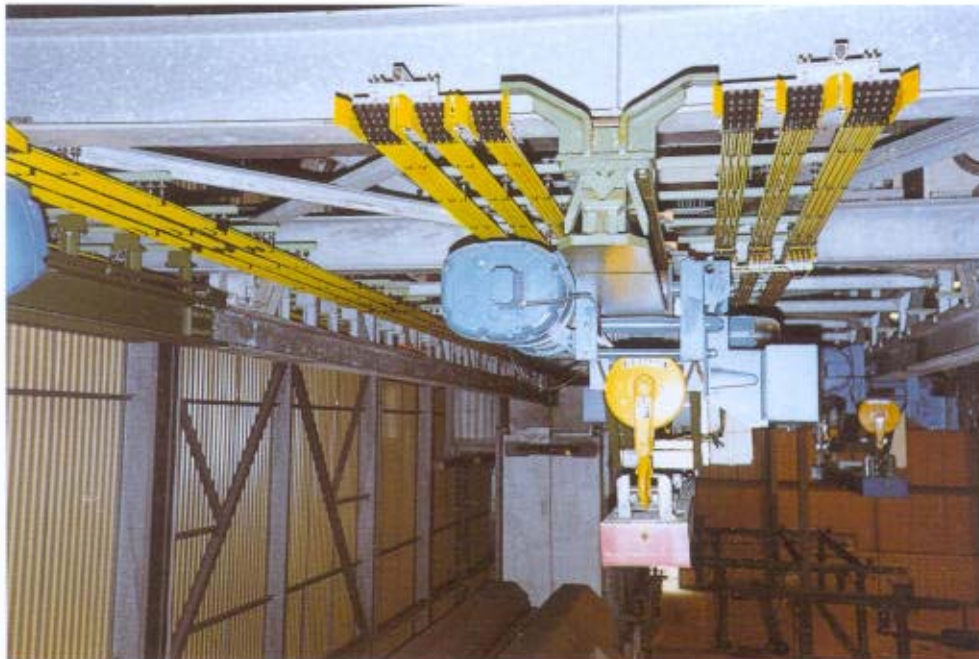

Automatic crane installation for transfer operation with pick up guides in a zinc coating plant.

Neither informations nor drawings to be reproduced without our prior permission. All data subject to engineering change.

DESCRIPTION

PROGRAMME 811

The **wamptler** 811 conductor rail system, is a modern power supply system using single-pole insulated conductor rails. It complies with the latest regulations and provides the electric energy supply for mobile consumers.

The usual applications of this conductor rail programme are electrical overhead mono rails, hoists, cranes, building machinery, transport vehicles, assembly lines, slip ring assemblies, special machines etc., for transmission of power, control and data signals, on both indoor and weather-protected outdoor installations.

The conductor rail material is copper (100 Amps nominal current), steel (32 Amps nominal current) and datametal (10 Amps nominal current). The conductor rails with any numbers of poles can be installed vertically or horizontally, or in curved systems. The conductor rails can be installed compactly with a spacing of 20 mm.

Note: When conductor rail systems are operated in aggressive environmental conditions, e.g. galvanizing or pickling plants etc., we must be informed about the environmental conditions.

For high ambient temperature conditions, a high temperature insulation cover up to +85° C is available. Generally, the insulation cover is 80 mm shorter than the length of the rail.

The entire conductor rail system is insulated to current Safety Regulations, it is entirely protected against direct contact. The earth insulation cover is marked yellow-green on both sides over the entire length of the rail.

The spring operated insulated collectors can accommodate vertical/horizontal misalignment and are available in single or double versions. Collectors can be supplied for use in vertical or horizontal applications and for discontinuous systems. The earth collector is colour identified and not interchangeable with a phase collector.

Installation of the conductor rail system is simple; maintenance is confined to a routine check of the collectors. Spare collector shoes can be changed quickly and safely.

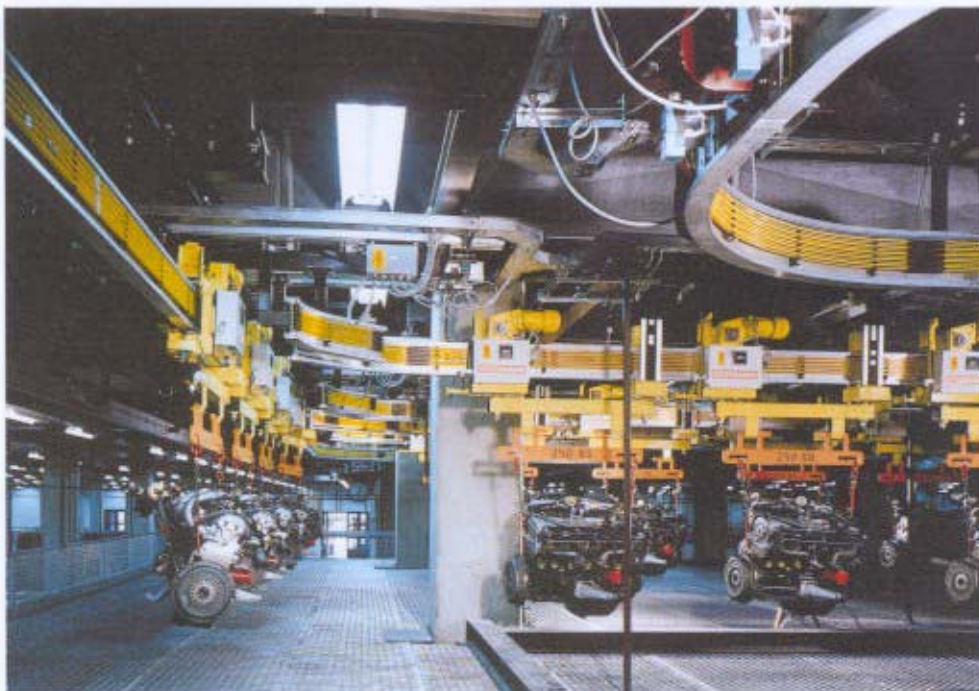

Back-up line installation of an electrically driven trolley conveyor for the transport of motors.

Please answer complete by the questionnaire – in this catalogue – and attach it to your enquiry.

REGULATIONS

The design of the system is based on the following regulations:

1. Protection against direct contact to DIN 57470 part 1 / VDE 0470 part 1 (IEC-testfinger) and DIN 57100 part 410 5.2.1/5.3 / VDE 0100 part 410 (protection class IP 23 to IEC 529), also DIN/VDE 0100 part 726 4.2
2. Protection against accidental interchanging of phase and earth collector to VDE 0100 part 726/4.1
3. Current carrying capacity to DIN 43670 and DIN 43671 for coated conductors (insulated conductor rails)
4. Surface creepage distance to VDE 0100 part 726 / 4.4
5. Surface creepage distance to VDE 0110 part 1 01.89 table 4

		Standard insulation	High temperature insulation
6. Surface creepage resistance	DIN 53480/VDE 0303 T1	KC > 600 V (CTI)	KC 500 V (CTI)
7. Dielectric strength	DIN 53481	22,4 kV/mm	50 kV/mm
8. Surface resistance	DIN 53482	$10^{13} \Omega$	$5,2 \times 10^{13} \Omega$
9. Specific resistance	DIN 53482	dry $8 \times 10^{15} \Omega \text{ cm}$ wet $2 \times 10^{15} \Omega \text{ cm}$	dry $1,4 \times 10^{14} \Omega \text{ cm}$
10. Combustibility of insulation cover to UL 94 at 3 mm a. 1,5 mm thickness		V - 0	V - 0
11. Chemical resistance	The materials of the conductor rail systems are weather-resisting and have a very good chemical resistance. For special applications please contact us.		

Use solvents and contact sprays with utmost caution.

TEST INSTRUMENTS AND PROCEDURES TO DIN 57470 PART 1 / VDE 0470 PART 1

IEC-TESTFINGER

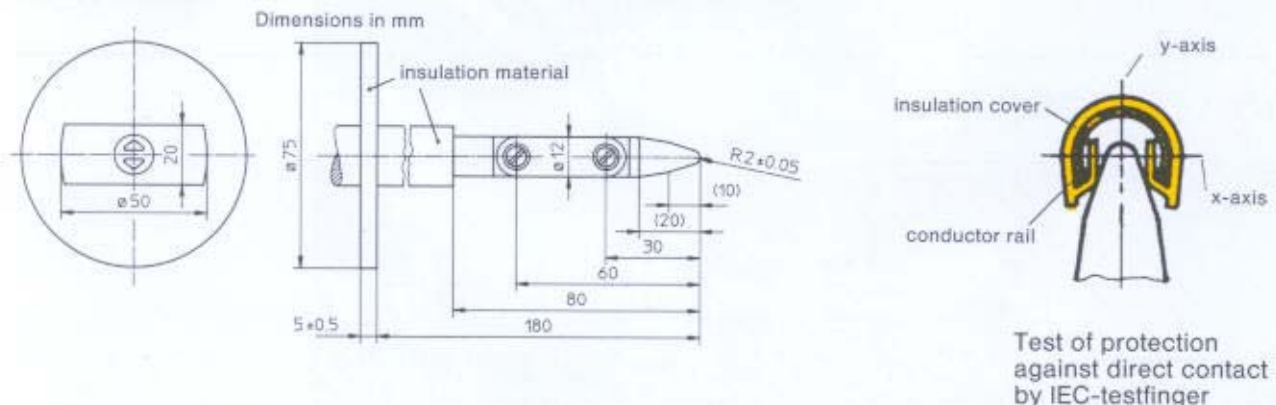

Similar or identical regulations are applicable in:

AUS: AS 1939	I: CEI 05515 and 09414
CH: SEV 3428, SN 411079	NL: NEN 2438 NEN 10034-5
F: NF C 20-010 NF EN 60034-5 NF C 51-115	S: SS IEC 529
GB: BS 5490	USA: UL inspection-no E 99342

The **wampfler**-insulated conductor rail system is entirely safe to operate at all points according to current safety regulations, even at maximum operating temperature. **Please check our statement!**

Conductor rail system		PROGRAMME 811		
Conductor rail		Galvanized Steel	Copper	Datametal
Type		081112	081116	081118
Nominal current at 100% DC and 35° C	[A]	32	100	10
D.C. resistance at +35° C	[Ω/m]	0,005506	0,000743	0,029313
at +20° C	[Ω/m]	0,005122	0,000703	0,029200
Impedance at 20 mm rail spacing and +35° C	[Ω/m]	0,005507	0,000750	0,029314
and +20° C	[Ω/m]	0,005124	0,000709	0,029202
Moment of Inertia	I_x [cm ⁴] I_y [cm ⁴]	0,024 0,048	0,024 0,048	0,024 0,048
Moment of resistance	W_x [cm ³] W_y [cm ³]	0,048 0,076	0,048 0,076	0,048 0,076
Voltage grade	[V]	500 within hand range 660 out of hand range		
Support spacing	[m]	between 0,4 and 1,0 (depending on application)		
Rail length	[mm]	4000		
Outside dimensions	[mm]	14,7 x 15,5		
Traveling speed	[m/min]	600 max.		
Expansion joint		not required up to 100 m installation length		
Permissible ambient temperature		-10° C ... +55° C (Standard insulation) } other temperatures -10° C ... +85° C (high temperature insulation) } on request		
Protection against direct contact		DIN 57470 part 1 / VDE 0470 part 1 and DIN 57100 part 410 5.2.1/5.3 / VDE 0100 part 410 and DIN/VDE 0100 part 726 4.2		
Breakdown voltage		DIN 53481	22,4 kV (Standard insulation cover) 50 kV (high temperature insulation cover)	

AMBIENT TEMPERATURE

Duty Cycle	100 %	80 %	60 %	40 %	20 %
Permissible ambient temperature for standard insulation	55° C	57,5° C	60° C	62,5° C	65° C
Permissible ambient temperature for high temperature insulation	85° C	92,5° C	100° C	107,5° C	110° C

SELECTION OF CONDUCTOR RAIL

The conductor rail must be selected, so that the total current does not exceed the listed ampere rating. The voltage drop on the conductor rail should normally not exceed 2.5 % of normal supply voltage. For installations in extreme ambient conditions please consult factory.

Formulae for the calculation of voltage drop:

AC three phase	$\Delta u = (\sqrt{3} \times I \times l / g \times Z)$ [V]	Δu	= Total drop	[V]
AC single phase	$\Delta u = (2 \times I \times l / g \times Z)$ [V]	I/g	= Total load	[A]
DC	$\Delta u = (2 \times I \times l / g \times R)$ [V]	R	= Conductor resistance	[Ω/m]
		Z	= Conductor impedance	[Ω/m]
		l	= feeder length	[m]

TECHNICAL EXPLANATION

1. INSULATED CONDUCTOR RAIL

The conductor rails are manufactured from copper (100 amps), zinc galvanized steel (32 amps) and data metal (10 amps). The plastic covered conductor rails are usually supplied 4000 mms long, **the insulation cover being 80mms shorter than the rail**. The conductor rail is insulated according to the current regulations (see chapter 'Specifications and Regulations'). The insulation cover for the earth conductor is coloured yellow/green on both sides to distinguish it from the phase conductors which have yellow insulation. The concave shape of the conductor rail provides accurate guidance of the collector shoe and ensures that the whole of the collector shoe is in contact with the conductor rail.

The data metal rail is suitable for transmission of data signals in series and is manufactured from a metal specially selected for this purpose. The data metal rail has been successfully used for transmitting data signals of 76800 Bits/sec at a current of 20 m. amps and a voltage of 5 volts. The fault rates are less than 10^{-9} at travelling speeds up to 200 metres per minute using standard components. Even when the system is installed in humid conditions and has not been used for long periods, the fault level does not increase. The characteristic resistance of the data metal is 75 ohms approximately.

2. RAIL CONNECTOR

The conductor rail sections are notched at both ends and can be easily joined together using the bayonet type rail connector, and therefore no tools are required. When joining the conductor rails it is advisable to install the rail connector before securing the conductor rail into the adjacent hanger clamps. The insulation joint cover fits over the rail connector to provide continuity of insulation. The rail connector metal is selected to be compatible with the conductor rail to prevent any electrolytic reaction.

3. EXPANSION JOINT

Expansion joints are required in installations over 100 metres in length, at expansion joints in buildings, for systems with curves and switches and where there is a large temperature variation. Expansion joints can be provided at any rail connection joint by lengthening the standard notch with the notching pliers. Each expansion joint can accommodate a 10 mm expansion.

4. POWER FEED

Powerfeed clamps or clips are used for connecting the incoming supply cable on to the conductor rail. The powerfeed clamp can be fitted at any rail connection joint and can be provided with terminal lugs or spades. Terminal lugs and spades are provided for 1 x 6 sq mm up to 2 x 10 sq mm. The powerfeed 081153 E can be fitted at any point on the conductor rail by making a hole in the insulation cover. The powerfeed clips 081154 are used within the end caps at switch positions. Cable up to 6 sq mm maximum can be fitted.

5. ISOLATING JOINT AND ISOLATING PIECE

These components are used for electrically separating the conductor rails to provide isolating sections and can be installed at any point on the conductor rail. Isolating joints (isolating distance 15 mms) are normally installed at conductor joint positions but they can be fitted at any point by removing the insulation cover, cutting and notching the conductor rail, fitting the isolating joint and replacing the insulation cover.

Isolating pieces can be installed at any point on the conductor rail by removing the rail, cutting the appropriate length of rail and inserting the isolating pieces (10, 15 or 38 mm segments) to form the isolating section of any length, then refitting the insulation cover. They are especially suitable for fitting on curves.

These components are principally designed for installations up to 50 volts. For higher voltages air gap isolating sections 081195 - 21 must be used.

6. ANCHOR CLAMP

The system is designed to expand/contract along its length however to control the movement equally in each direction anchor clamps are fitted, normally at the centre of the system, or between adjacent expansion joints. They should never be fitted at the end of a system.

Two anchor clamps fitted on either side of a hanger clamp form an anchor point.

Anchor clamps 081131, 081132 secure the insulation cover and hold the conductor rail at the rail connector position. Using these anchor clamps a 10 mm movement of the conductor rail is possible if this is not acceptable 081153 F clamp should be used.

At switches anchoring is achieved via the end caps which are fixed by their mounting bolts.

7. END CAP FOR RAIL ENDS AND TRANSFER POINTS

Straight and oblique type end caps are used at switches to provide transfer points. These end caps provide easy and smooth traversing of the collectors across the transfer points and can accommodate vertical or horizontal misalignment of ± 5 mm. The air gap between two opposite mounted end caps should not exceed 5 mm. For larger misalignments of either ± 10 mm or ± 30 mm pick-up guides are available. Please consult us for any special requirements.

8. HANGER CLAMP

Various composite hanger clamps are available in 3, 4, 5 or 6 pole versions.

The hanger clamps are manufactured from plastic material and allow the conductor rail to be „snapped“ in.

9. PICK-UP GUIDE

Pick-up guides are designed to transfer collectors onto the conductor rail on discontinuous circuits, transfer switches, lift stations and turntables where there are large misalignments. Two standard types are available which can accommodate ± 10 or ± 30 mms tolerances.

Please consult us for larger tolerances and high speed applications.

10. CURRENT COLLECTOR

The current collector can articulate in all directions and is fully insulated. It can be installed in either the horizontal or vertical plane and will accommodate misalignments of ± 10 mms, ± 16 mms to ± 30 mms or, ± 10 mms, ± 20 mms to ± 30 mms respectively. A special spring system self centres the collector.

For curved systems care should be taken when selecting the collector position that the tolerances are not exceeded when the collector travels around the curve.

To maintain electrical continuity at transfer points when end caps have been used, double collectors should be used. Collectors for systems with pick-up guides must be fitted with distance pieces (see sections 10.1, 10.3, 10.4 and 10.8).

When the collector is travelling in two directions the stabilising spring should be fitted into the lower hole. For uni directional use the spring is fitted into the higher hole to compensate for the torque created by the sliding friction between collector shoe and conductor rail. The wear life of the collector shoe can be increased by as much as 25%. For installations with pick-up guides current collectors for transfers have to be used as they are equipped with distance pieces.

Highly flexible cable tails are available for the 40 mm long collector shoe in sizes up to 4 sq mm fitted with a terminal lug and for the 63 mm long collector shoe up to 6 sq mm prepared for screw connection.

The earth collector is coloured yellow-green and when fitted onto the 020 194 towing arm cannot be accidentally placed into a phase conductor rail due to the design of the collector base.

The voltage drop between the collector shoe and conductor rail is 0.1 volt at 5 N contact pressure.

The collector shoes can be checked for wear without dismounting and are easily replaced.

11. SPARE PARTS

Collector shoes: Replacement collector shoes are supplied complete with collector case.

Stabilising Spring: If the stainless steel spring is deformed it must be replaced.

12. ACCESSORIES

The cable connections shown in section „accessories“ should always be used with current collectors and power-feeds to guarantee a correct electrical connection.

13. TOOLS

The **wamptler** insulated conductor rail system can be installed with standard tools (hacksaw, cutting pliers).

However, we have available special cutting and notching pliers which reduce installation time.

Conductor can easily be bent on site to a 500 mm minimum radius curve using a three roller portable bending machine. Alternatively curves are available ex works.

The tools can be loaned or purchased.

Note:

The plastic parts are manufactured from self extinguishing material (see chapter 'Specifications and Regulations'). All steel parts are galvanised except where stated.

PARTS OF THE CONDUCTOR RAIL SYSTEM

1. INSULATED CONDUCTOR RAILS (see technical explanation)

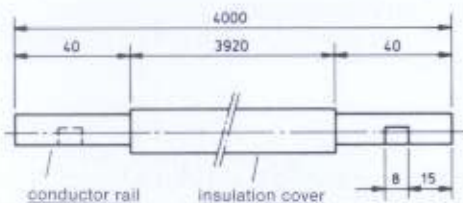

The earth conductor insulation cover is marked **yellow-green on both sides**.



Standard insulation suitable from -10°C to $+55^{\circ}\text{C}$ ambient temperature (other temperatures on request).
High temperature insulation suitable from -10°C to $+85^{\circ}\text{C}$ ambient temperature (other temperatures on request).

1.1 Steel Rail 081112 galvanized 32 Amps

Type	Order-no		Length [m]	Weight [kg]
	phase conductor	earth conductor		
Steel Rail 32 Amps with standard insulation	081112-4x11	081112-4x12	4	1,180
Steel Rail 32 Amps with high temperature insulation	081112-4x21	081112-4x22	4	1,180

1.2 Copper Rail 081116 100 Amps

Type	Order-no		Length [m]	Weight [kg]
	phase conductor	earth conductor		
Copper Rail 100 Amps with standard insulation	081116-4x11	081116-4x12	4	1,280
Copper Rail 100 Amps with high temperature insulation	081116-4x21	081116-4x22	4	1,280

1.3 Datametal Rail 081118 10 Amps

Type	Order-no		Length [m]	Weight [kg]
	phase conductor	earth conductor		
Datametal Rail 10 Amps with standard insulation	081118-4x11	081118-4x12	4	1,200
Datametal Rail 10 Amps with high temperature insulation	081118-4x21	081118-4x22	4	1,200

2. RAIL CONNECTOR (see technical explanation)

2.1 Rail Connector 081121 and 081122

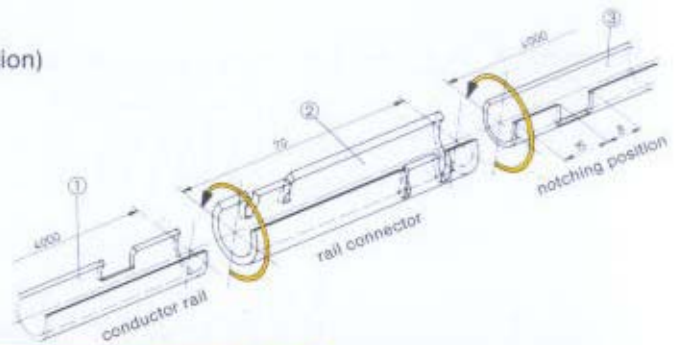
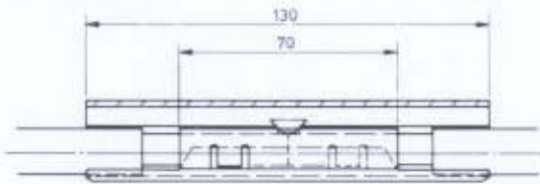

Type	Order-no	Weight [kg]
Rail Connector with insulation cover, one-part, for steel and datametal rail	081121 - 2	0,048
Rail Connector with insulation cover, one-part, for copper rail	081121 - 6	0,050
Rail Connector with insulation cover, two-part, for steel and datametal rail	081122 - 2	0,048
Rail Connector with insulation cover, two-part, for copper rail	081122 - 6	0,050

Mounting procedure:

I Turn the rail connector ② into the conductor rail ①

II conductor rail ③ is turned into the rail connector ②

3. EXPANSION JOINT (see technical explanation)

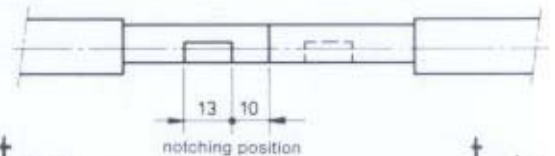
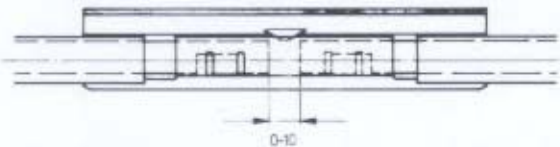

Normally expansion joints are not required when systems are installed in situations where there is very small temperature variation, i.e. car plants etc.

In applications with large temperature variation, expansion joints must be used in accordance with diagram 1. Expansion joints are created by enlarging the notch in the conductor rail with notching pliers 081082 (Position D), 10 mms expansion at each rail connector is then available. The standard rail connector 081121 is still used.

On installation of expansion joints the conductor rail ends should be lubricated with non-resinous grease (Vaseline) and anchor clamps fitted on either side of the middle hanger clamp between expansion joints (see diagram 4). The number of expansion joints per installation length can be taken from diagram 2 and 3. The air gap should be adjusted in accordance with the ambient temperature (see diagram 1) and rechecked after the installation is completed.

Diagram 1

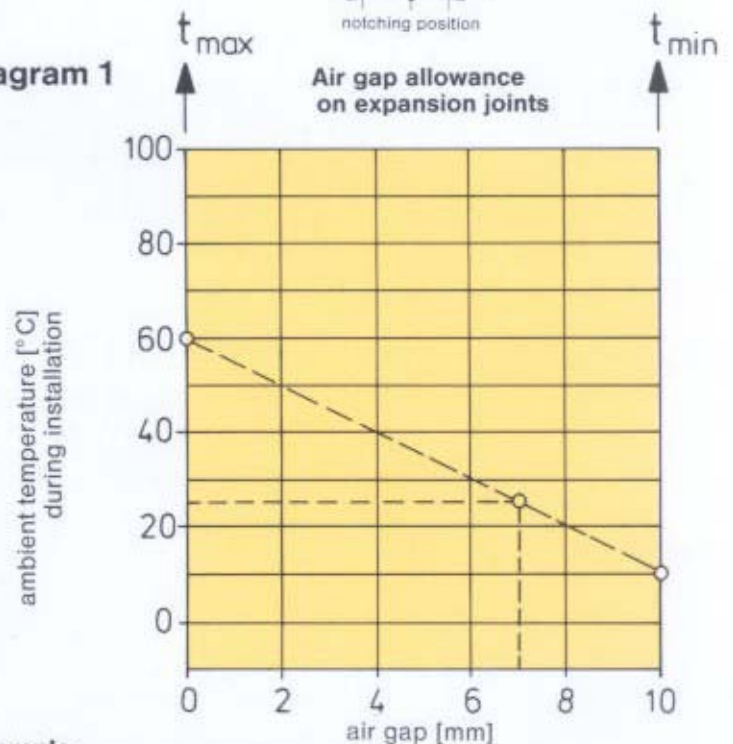

Example:

Temperature range from +10°C up to +60°C
(ambient temperature during installation: +25°C).

Instruction:

t_{min} = lowest temperature that occurs in the respective area of application.

t_{max} = highest operational temperature that occurs in the respective area of application.

1. Draw a connecting line from t_{min} to t_{max} .
2. Mark the ambient temperature during operation horizontally.
3. Draw a line from the intersection vertically down and read the air gap to be set.

Diagram 2

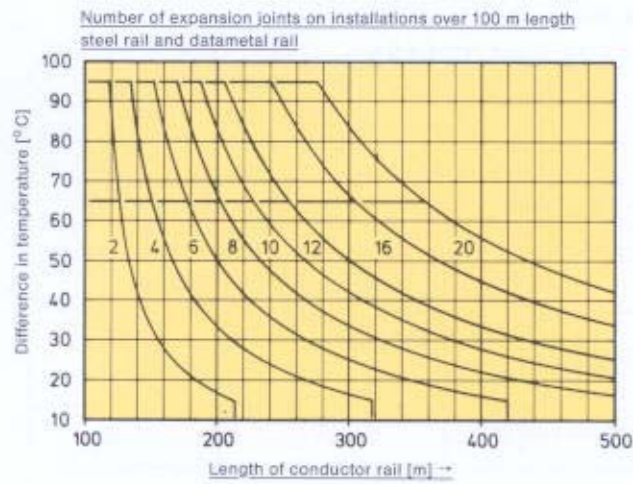
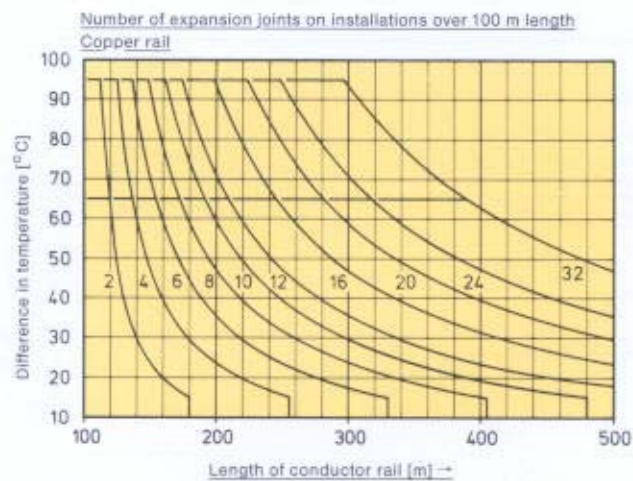

Diagram 3



$$\text{Difference of temperature} = \Delta t_U + \Delta t_{sw}$$

Δt_U = temperature range of ambient temperature

Δt_{sw} = temperature rise due to current heating

$\Delta t_{sw} = 5^\circ$ up to 50% duty cycle

$= 10^\circ$ up to 100% duty cycle

Diagram 4

EJ = expansion joint

AP = anchor point

L = total length of conductor rail installation

a = intermediate length for 2 expansion joints

$$a = \frac{(L - 100) \cdot 2}{\text{number of expansion joints}}$$

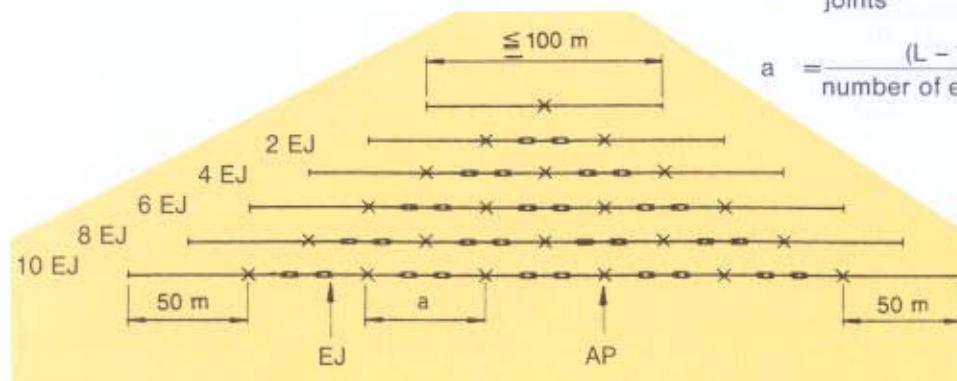

2 expansion joints are installed in the middle between 2 anchor points.

4. POWER FEEDS (see technical explanation)

4.1 Power Feed 081151 and 081156

max. 35 Amps
for phase and control conductor

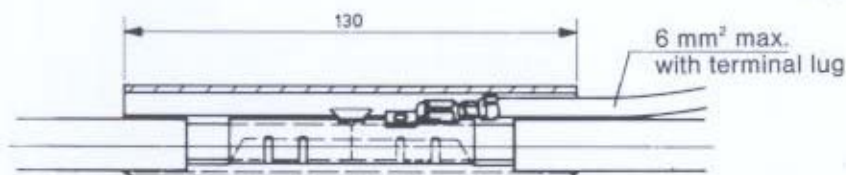

Type	Order-no	Weight [kg]
Power Feed 6 mm ² with insulation cover, one-part, for steel and datametal rail	081151 - 21	0,050
Power Feed 6 mm ² with insulation cover, one-part, for copper rail	081151 - 61	0,052
Power Feed 6 mm ² with insulation cover, two-part, for steel and datametal rail	081156 - 21	0,050
Power Feed 6 mm ² with insulation cover, two part, for copper rail	081156 - 61	0,052

connection with insulated terminal lug
(see section 12.1 and 12.2)

Max. cable outside diameter 9 mm.

4.2 Power Feed 081151 and 081156

max. 45 Amps
for phase, control and earth conductor

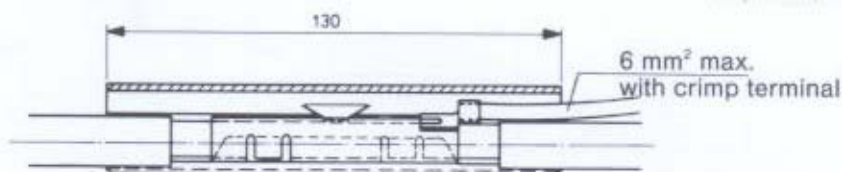

Type	Order-no	Weight [kg]
Power Feed 6 mm ² with insulation cover, one-part, for steel and datametal rail	081151 - 22	0,050
Power Feed 6 mm ² with insulation cover, one-part, for copper rail	081151 - 62	0,052
Power Feed 6 mm ² with insulation cover, two-part, for steel and datametal rail	081156 - 22	0,050
Power Feed 6 mm ² with insulation cover, two-part, for copper rail	081156 - 62	0,052

connection of the cable with crimping tool

Max. cable outside diameter 9 mm.

4.3 Power Feed 081155 and 081157

max. 100 Amps
for phase, control and earth conductor

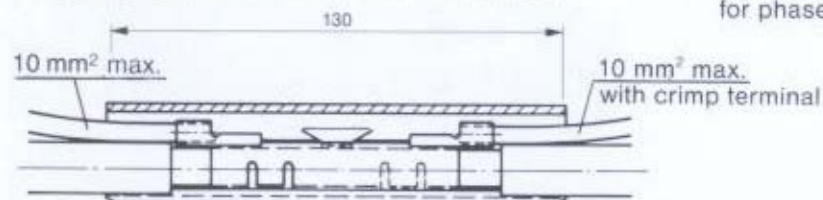

Type	Order-no	Weight [kg]
Power Feed 2 x 10 mm ² with insulation cover one-part	081155 - 62	0,070
Power Feed 2 x 10 mm ² with insulation cover two-part	081157 - 62	0,070

connection of the cable with crimping tool

Max. cable outside diameter 9 mm.

4.4 POWER FEED CLAMP 081153 E

(max. 45 Amps)

for phase and control conductor

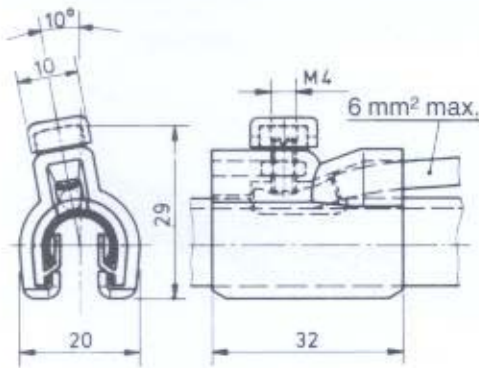

If the power feed clamp is used as a feed point a hole is punched into the insulation cover by the insulation punching device 081084 to connect the feeder cable to the rail. This clamp is suitable especially for power feeds on curves or when isolating pieces 081193 are used for control sections.



Connection with multicore cable end (4 to 6 mm², see section 12.7) and flat contact tongue (1.5 to 2.5 mm², see section 12.3)

Type	Order-no	Weight [kg]
Power Feed Clamp	081153 E	0,010

4.5 Power Feed Clip 081154 – 21 and 081154 – 61

for end feed in end caps
(max. 6 mm², 35 Amps however)
for phase and control conductor

connection with
insulated terminal lug

Please note: The power feed clip must be turned on to the rail!
(arrangement, see photo section 7.2)

Type	Order-no	Weight [kg]
Power Feed Clip for steel and datametal rail	081154 – 21	0,005
Power Feed Clip for copper rail	081154 – 61	0,005

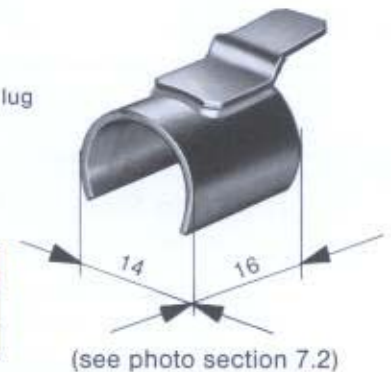

4.6 Power Feed Clip 081154 – 22 and 081154 – 62

for end feed in end caps
(max. 6 mm², 45 Amps)
for phase, control and earth conductor

connection of the
cable with
crimping tool

Please note: The power feed clip must be turned on to the rail!
(arrangement, see photo section 7.2)

Type	Order-no	Weight [kg]
Power Feed Clip for steel and datametal rail	081154 – 22	0,005
Power Feed Clip for copper rail	081154 – 62	0,005

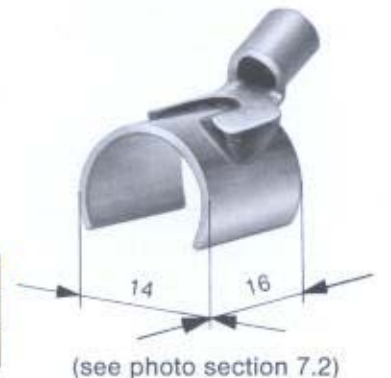

10-pole electrically driven switch for a trolley conveyor with variable feed points.



5. ISOLATING JOINT and AIR GAP ISOLATING SECTION (see technical explanation)

5.1 Isolating Joint 081191 and 081192

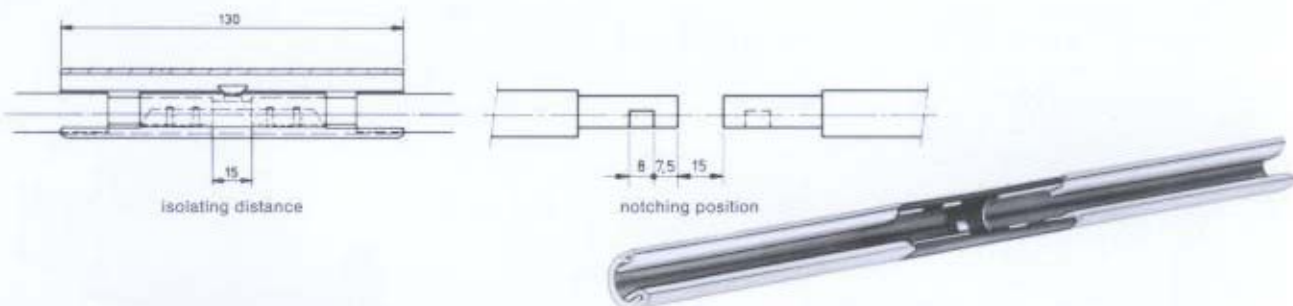

Type	Order-no	Weight [kg]
Isolating Joint with insulation cover, one-part	081191 - 15	0,026
Isolating Joint with insulation cover, two-part	081192 - 15	0,036

5.2 Isolating Piece 081193

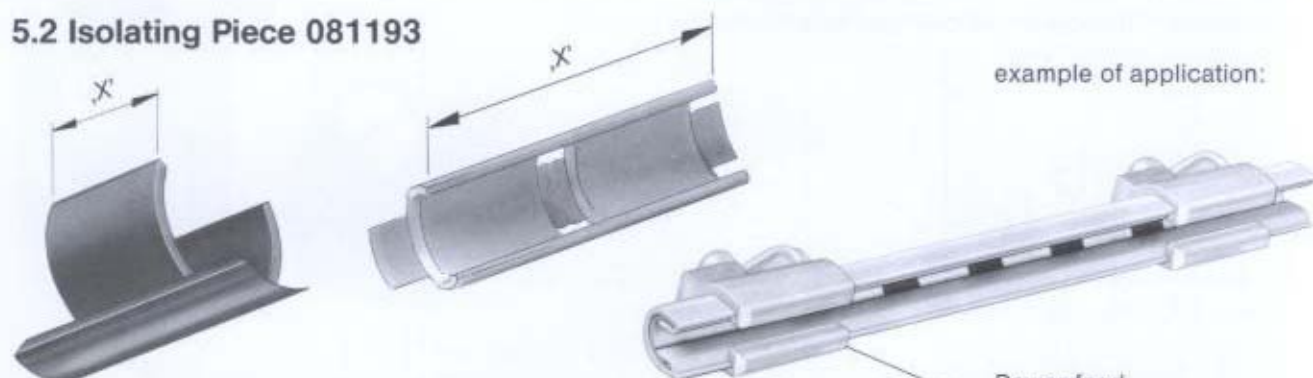

Type	Isolation Distance 'x'	Order-no	Weight [kg]
Isolating Piece	10 mm	081193 - 10	0,001
Isolating Piece	15 mm	081193 - 15	0,002
Isolating Piece	38 mm	081193 - 38	0,004

example of application:

Power feed clamp 081153 E or anchor clamp 081153 F. must be fitted to eliminate movement of the rail.

5.3 Air Gap Isolating Section 081195

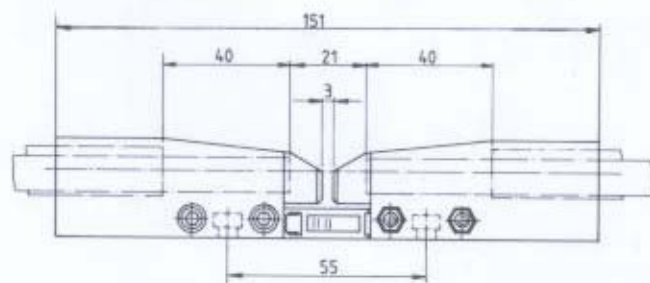

Design

In principle, the air gap isolating section consists of two opposing end caps which are connected to each other, in a rigid way, by notched catches. The insulating distance of the conductor rail is 21 mm including an air gap separation is 3 mm.

Assembly

The sketch shows, that for the installation of the air gap isolating section, a distance of 21 mm is required between the conductor rails. The insulating profile must be 80 mm shorter than the length of the rail. Because of the rigid design, no additional fixing material is required in straight installations. For installation on curves the unit must be supported via an M5 bolt, to a bracket, if the radius is less than 2 m (see 081172 end cap). Feed points can be arranged on each side as available for the end caps.

Type	Order-no	Weight [kg]
Air Gap Isolating Section	081195 - 21	0,046

6. ANCHOR CLAMPS (see technical explanation)

6.1 Anchor Clamp 081153 F

Use of the power feed clamp 081153 E as an anchor clamp preferably for installations with insulating sections using isolating piece 081193.



Type	Order-no	Weight [kg]
Anchor Clamp	081153 F	0,010

Please note: If the power feed clamp is used as an anchor clamp no hole must be punched into the insulation cover because the screw of the power feed clamp must clamp the insulation cover.

6.2 Anchor Clamp 081131 and 081132

Only for installations without insulating sections.

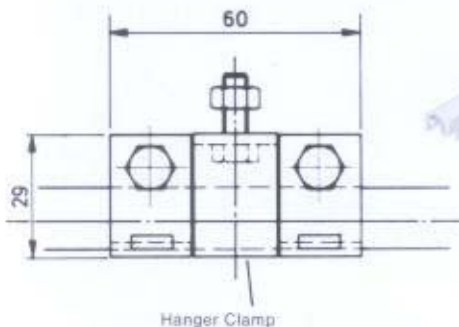

Anchor clamp with recess 081131 for lack of space in corners

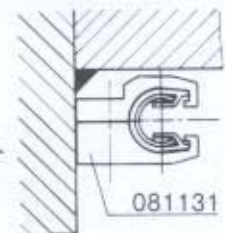

Type	Order-no	Weight [kg]
Anchor Clamp with recess	081131	0,010
Anchor Clamp without recess	081132	0,014

7. END CAPS FOR RAIL ENDS AND TRANSFER POINTS (see technical explanation)

7.1 End Cap 081173

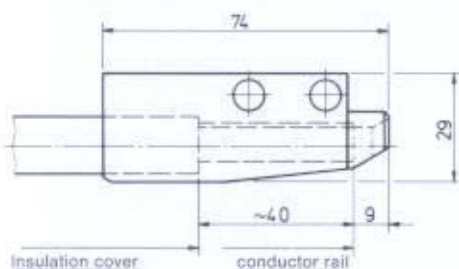

Short type without mounting bolts for ends and interruptions.

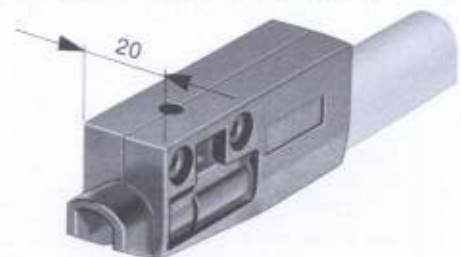

To compensate for misalignment of horizontal and vertical deflections of max. ± 1 mm

Type	Order-no	Weight [kg]
End Cap 1-pole	081173 - 20 x 1 x 0	0,020

7.2 End Cap 081173

Short type
with power feed max. 6 mm²
without mounting bolts
for ends and
interruptions.



To compensate for misalignment of horizontal
and vertical deflections of max. ± 1 mm



Type	Order-no		Weight [kg]
End Cap 1-pole for steel and datametal rail	for phase and control conductor up to 6 mm ²	081173 - 20 x 1 x 21	0,025
End Cap 1-pole for copper rail		081173 - 20 x 1 x 61	0,025
End Cap 1-pole for steel and datametal rail	for phase, control and earth conductor up to 6 mm ²	081173 - 20 x 1 x 22	0,025
End Cap 1-pole for copper rail		081173 - 20 x 1 x 62	0,025

7.3 End Cap 081172

Short type
with mounting bolts
for ends and
interruptions.

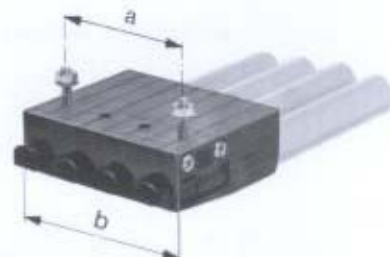
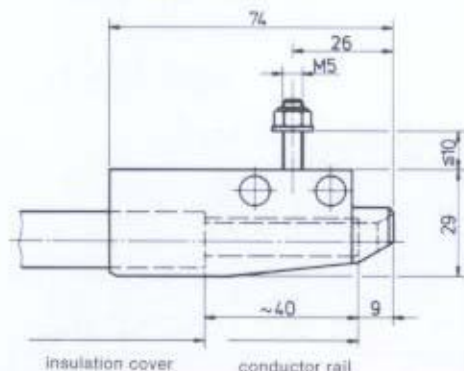

To compensate for misalignment of
horizontal and vertical deflections of max. ± 1 mm

Type	Order-no	Number of poles	Dimension 'a' [mm]	Dimension 'b' [mm]	Weight [kg]
End Cap 3-pole	081172 - 20 x 3 x 0	3	40	60	0,075
End Cap 4-pole	081172 - 20 x 4 x 0	4	60	80	0,095
End Cap 5-pole	081172 - 20 x 5 x 0	5	40	100	0,115
End Cap 6-pole	081172 - 20 x 6 x 0	6	60	120	0,135

7.4 End Cap 081172

Short type
with power feed max. 6 mm²
and mounting bolts for ends
and interruptions.

To compensate for misalignment of horizontal
and vertical deflections of max. ± 1 mm

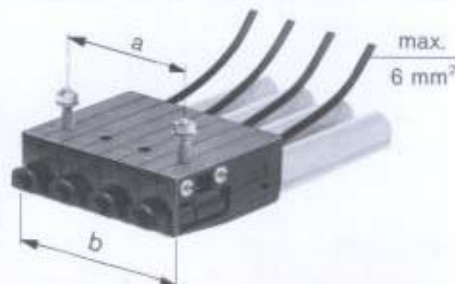

Type	Order-no		Number of poles	Dimension 'a' [mm]	Dimension 'b' [mm]	Weight [kg]
	for steel and datametal rail	for copper rail				
End Cap 3-pole	081172 - 20 x 3 x 2	081172 - 20 x 3 x 6	3	40	60	0,080
End Cap 4-pole	081172 - 20 x 4 x 2	081172 - 20 x 4 x 6	4	60	80	0,100
End Cap 5-pole	081172 - 20 x 5 x 2	081172 - 20 x 5 x 6	5	40	100	0,120
End Cap 6-pole	081172 - 20 x 6 x 2	081172 - 20 x 6 x 6	6	60	120	0,140

7.5 End Cap 081174

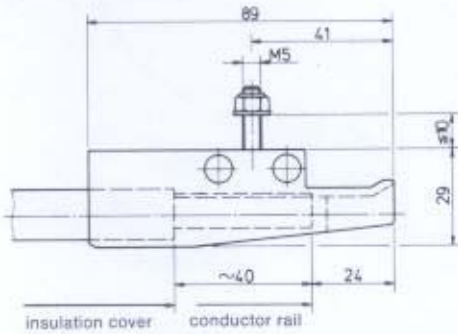

Long type with mounting bolts for switches

To compensate for misalignment of horizontal and vertical deflections of max. ± 5 mm

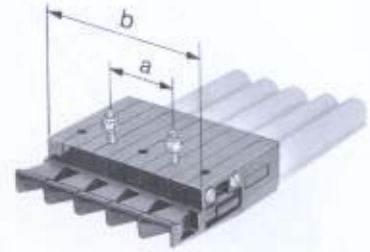

Type	Order-no	Number of poles	Dimension ,a' [mm]	Dimension ,b' [mm]	Weight [kg]
End Cap 3-pole	081174 - 20 x 3 x 0	3	40	60	0,090
End Cap 4-pole	081174 - 20 x 4 x 0	4	60	80	0,115
End Cap 5-pole	081174 - 20 x 5 x 0	5	40	100	0,140
End Cap 6-pole	081174 - 20 x 6 x 0	6	60	120	0,165

7.6 End Cap 081174

Long type with power feed max. 6 mm² and mounting bolts for switches

To compensate for misalignment of horizontal and vertical deflections of max. ± 5 mm

Type	Order-no		Number of poles	Dimension ,a' [mm]	Dimension ,b' [mm]	Weight [kg]
	for steel and datametal rail	for copper rail				
End Cap 3-pole	081174 - 20 x 3 x 2	081174 - 20 x 3 x 6	3	40	60	0,095
End Cap 4-pole	081174 - 20 x 4 x 2	081174 - 20 x 4 x 6	4	60	80	0,120
End Cap 5-pole	081174 - 20 x 5 x 2	081174 - 20 x 5 x 6	5	40	100	0,145
End Cap 6-pole	081174 - 20 x 6 x 2	081174 - 20 x 6 x 6	6	60	120	0,170

Arrangement of different end caps for switches in vertical conductor rail arrangements

Example 1: outer curve

Example 2: inner curve

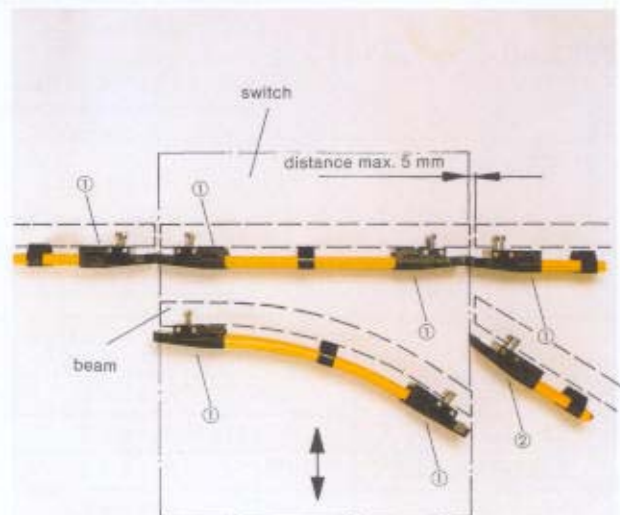
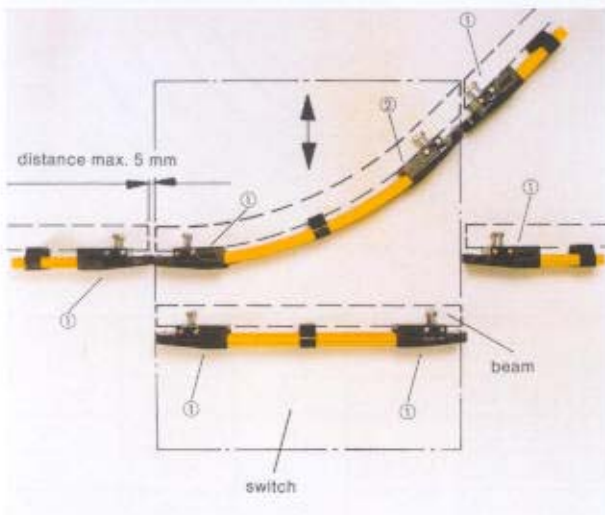

- ① = End Cap 081174
- ② = End Cap 081175

7.7 End Cap 081175

Long oblique type
with mounting bolts
for switches

To compensate for misalignment
of horizontal and vertical
deflections of max. ± 5 mm

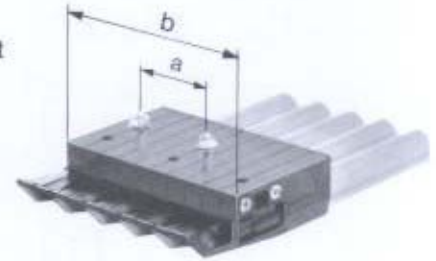
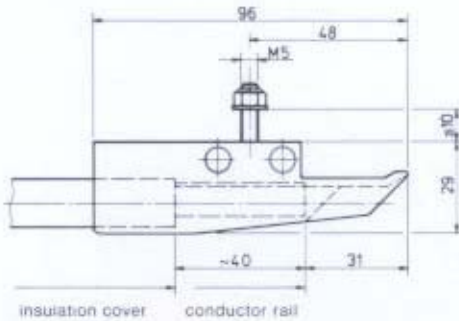

Type	Order-no	Number of poles	Dimension ,a' [mm]	Dimension ,b' [mm]	Weight [kg]
End Cap 3-pole	081175 - 20 x 3 x 0	3	40	60	0,090
End Cap 4-pole	081175 - 20 x 4 x 0	4	60	80	0,115
End Cap 5-pole	081175 - 20 x 5 x 0	5	40	100	0,140
End Cap 6-pole	081175 - 20 x 6 x 0	6	60	120	0,165

7.8 End Cap 081175

Long oblique type
with power feed max. 6 mm² with mounting bolts
for switches

To compensate for misalignment of horizontal
and vertical deflections of max. ± 5 mm

Type	Order-no		Number of poles	Dimension ,a' [mm]	Dimension ,b' [mm]	Weight [kg]
	for steel and datametal rail	for copper rail				
End Cap 3-pole	081175 - 20 x 3 x 2	081175 - 20 x 3 x 6	3	40	60	0,095
End Cap 4-pole	081175 - 20 x 4 x 2	081175 - 20 x 4 x 6	4	60	80	0,120
End Cap 5-pole	081175 - 20 x 5 x 2	081175 - 20 x 5 x 6	5	40	100	0,145
End Cap 6-pole	081175 - 20 x 6 x 2	081175 - 20 x 6 x 6	6	60	120	0,170

Sliding switch for continuous
passage at the branch-off
of an electrically
driven trolley conveyor.



7.9 End Cap 081176

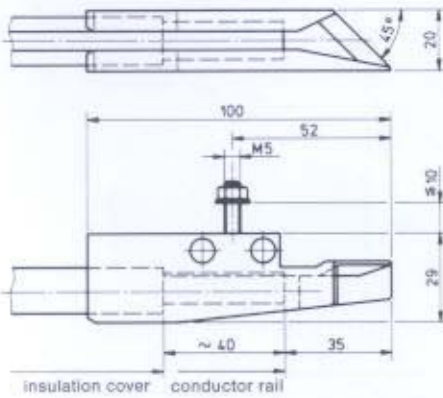

Horizontal, right oblique type
with mounting bolts
for transfer points in switches

To compensate for
misalignment of horizontal
and vertical
deflections of ± 5 mm.

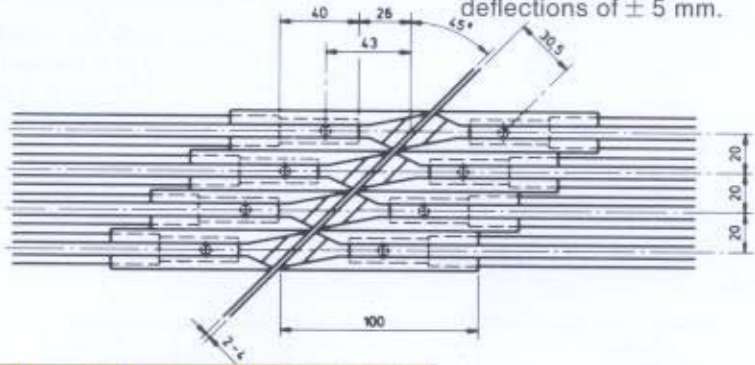

Type	Order-no	Weight [kg]
End Cap horizontal, right oblique type	081176	0,050

7.10 End Cap 081176

Horizontal, right oblique type
with power feed max. 6 mm² and mounting bolts
for transfer points in switches

To compensate for misalignment
of horizontal and vertical
deflections of max. ± 5 mm

Type	Order-no	Weight [kg]	
End Cap horizontal, right oblique type for steel and datametal rail	for phase and control conductor up to 6 mm ²	081176 - 21	0,055
End Cap horizontal, right oblique type for copper rail		081176 - 61	0,055
End Cap horizontal right oblique type for steel and datametal rail	for phase, control and earth conductor up to 6 mm ²	081176 - 22	0,055
End Cap horizontal, right oblique type for copper rail		081176 - 62	0,055

Arrangement of end caps for switches in horizontal conductor rail arrangements

Example 1:

Example 2:

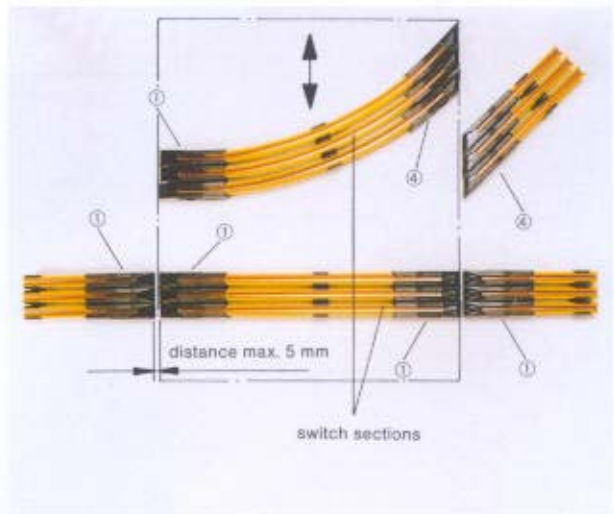
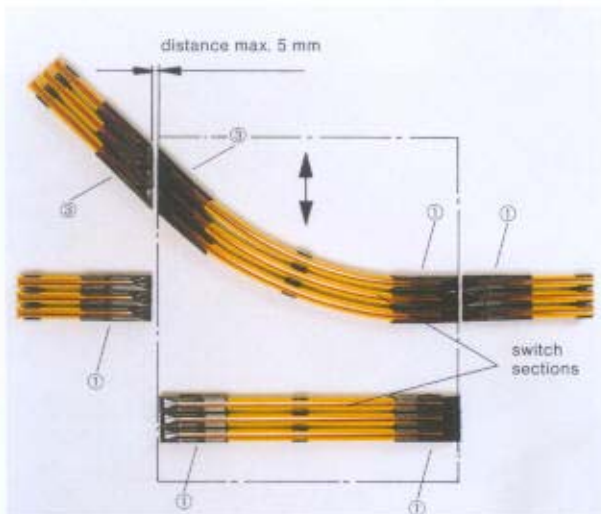

① = End Cap 081174
③ = End Cap 081176

① = End Cap 081174
④ = End Cap 081177

7.11 End Cap 081177

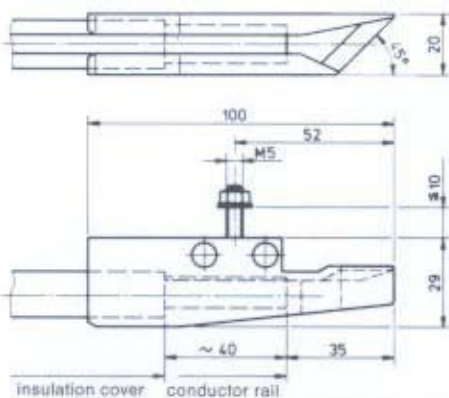

Horizontal, left oblique type with mounting bolts for transfer points in switches.

To compensate for misalignment of horizontal and vertical deflections of ± 5 mm.



Type	Order-no	Weight [kg]
End Cap horizontal, left oblique type	081177	0,050

7.12 End Cap 081177

Horizontal, left oblique type with power feed max. 6 mm² and mounting bolts for transfer points in switches

To compensate for misalignment of horizontal and vertical deflections of max. ± 5 mm

Type	Order-no	Weight [kg]	
End Cap horizontal, left oblique type for steel and datametal rail	for phase and control conductor up to 6 mm ²	081177 - 21	0,055
End Cap horizontal, left oblique type for copper rail		081177 - 61	0,055
End Cap horizontal, left oblique type for steel and datametal rail	for phase, control and earth conductor up to 6 mm ²	081177 - 22	0,055
End Cap horizontal, left oblique type for copper rail		081177 - 62	0,055

7.13 End Cap 081178 with clip

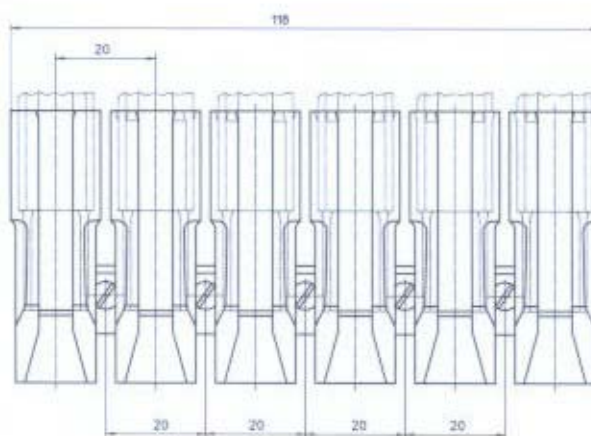

To compensate for misalignment of horizontal and vertical deflections of max. ± 2 mm.

Type	Order-no	Weight [kg]
End Cap with clip, 6-pole	081178 - 6	0,065

8. HANGER CLAMP (see technical explanation)

Advantages of **wampfler** rail holder are:

- easy snap-in installation of the conductor rails
- free thermal expansion because of free axial movement of the conductor rails
- installation on beams or **wampfler** support arms as well as on **wampfler** C-rails

Please note: For installation of hanger clamps 081145 on **wampfler** support arms 020185/020186 a washer R 6.6 DIN 440-St must be used (see sketch - 'system arrangement' - page 35)

with steel nut



for support arm installation



8.1 Hanger Clamp

3 pole

Hanger Clamp 081143 - 1 x 3 x 20

Hanger Clamp 081145 - 1 x 3 x 20

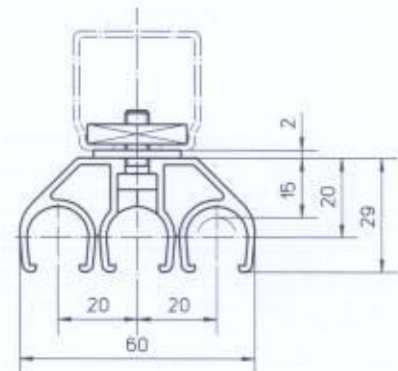
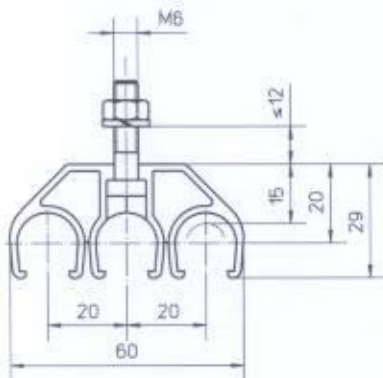

Type	Order-no	Weight [kg]
Hanger Clamp 3-pole	081143 - 1 x 3 x 20	0,030

Type	Order-no	Weight [kg]
Hanger Clamp 3-pole	081145 - 1 x 3 x 20	0,060

8.2 Hanger Clamp

4 pole

Hanger Clamp 081143 - 1 x 4 x 20

Hanger Clamp 081145 - 1 x 4 x 20

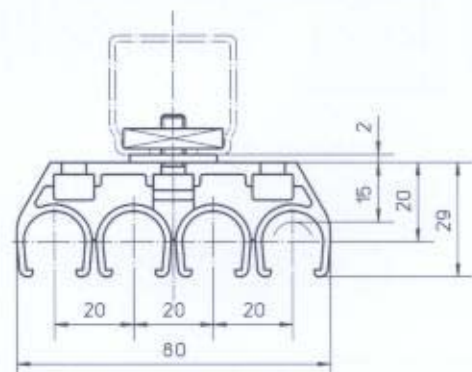
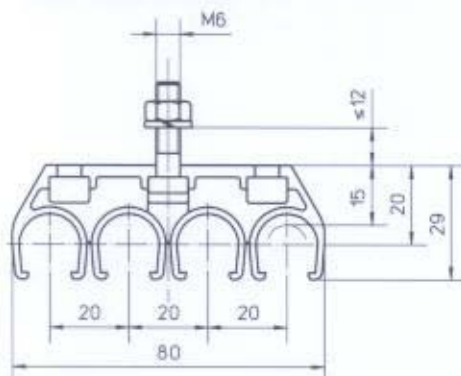

Type	Order-no	Weight [kg]
Hanger Clamp 4-pole	081143 - 1 x 4 x 20	0,035

Type	Order-no	Weight [kg]
Hanger Clamp 4-pole	081145 - 1 x 4 x 20	0,065

8.3 Hanger Clamp

5 pole

Hanger Clamp 081143 – 1 x 5 x 20

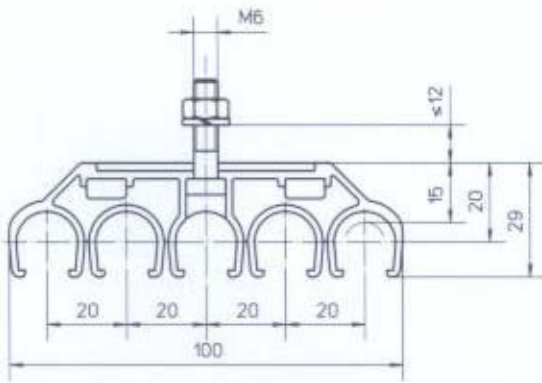

Type	Order-no	Weight [kg]
Hanger Clamp 5-pole	081143 – 1 x 5 x 20	0,040

Hanger Clamp 081145 – 1 x 5 x 20

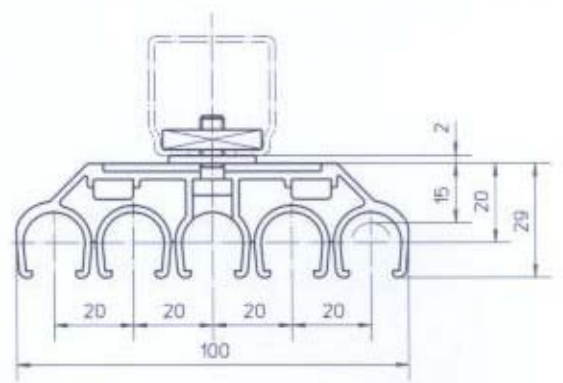

Type	Order-no	Weight [kg]
Hanger Clamp 5-pole	081145 – 1 x 5 x 20	0,070

8.4 Hanger Clamp

6 pole

Hanger Clamp 081143 – 1 x 6 x 20

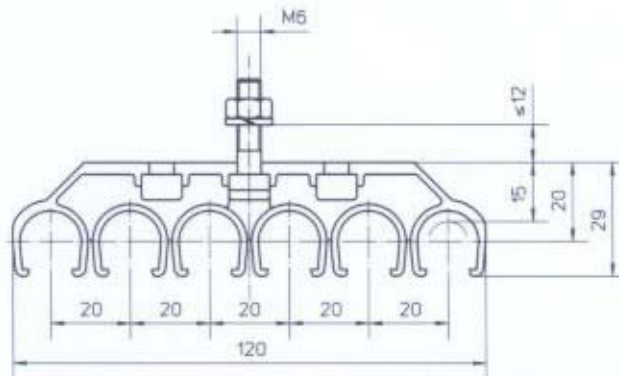

Type	Order-no	Weight [kg]
Hanger Clamp 6-pole	081143 – 1 x 6 x 20	0,045

Hanger Clamp 081145 – 1 x 6 x 20

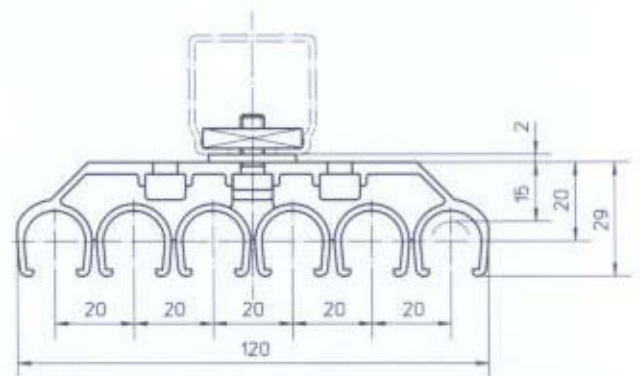

Type	Order-no	Weight [kg]
Hanger Clamp 6-pole	081145 – 1 x 6 x 20	0,075

8.5 Support Spacing

Table 1

Conductor Rail	max. Support Spacing 'A' [m]		
	el. overhead mono rails	crane installations	curved installations
Steel Rail	0,8	1,0	0,4
Copper Rail	0,5	0,8	0,4
Datametal Rail	0,8	1,0	0,4

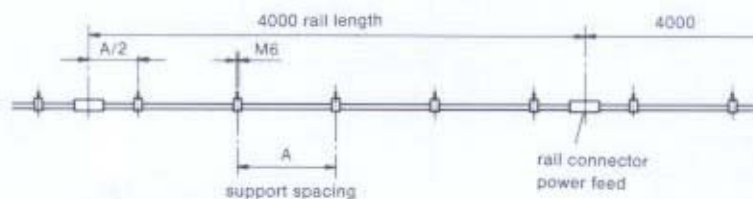

9. PICK-UP GUIDES FOR TRANSFER POINTS WITH LARGE TOLERANCES

9.1 Pick-up guide 081182 (see technical explanation)

Short type

for current collectors short type 081101
and current collectors long type 081102
for transfer operation.

To compensate for misalignment
of horizontal deflections ± 15 mm
and vertical deflections of ± 8 mm.

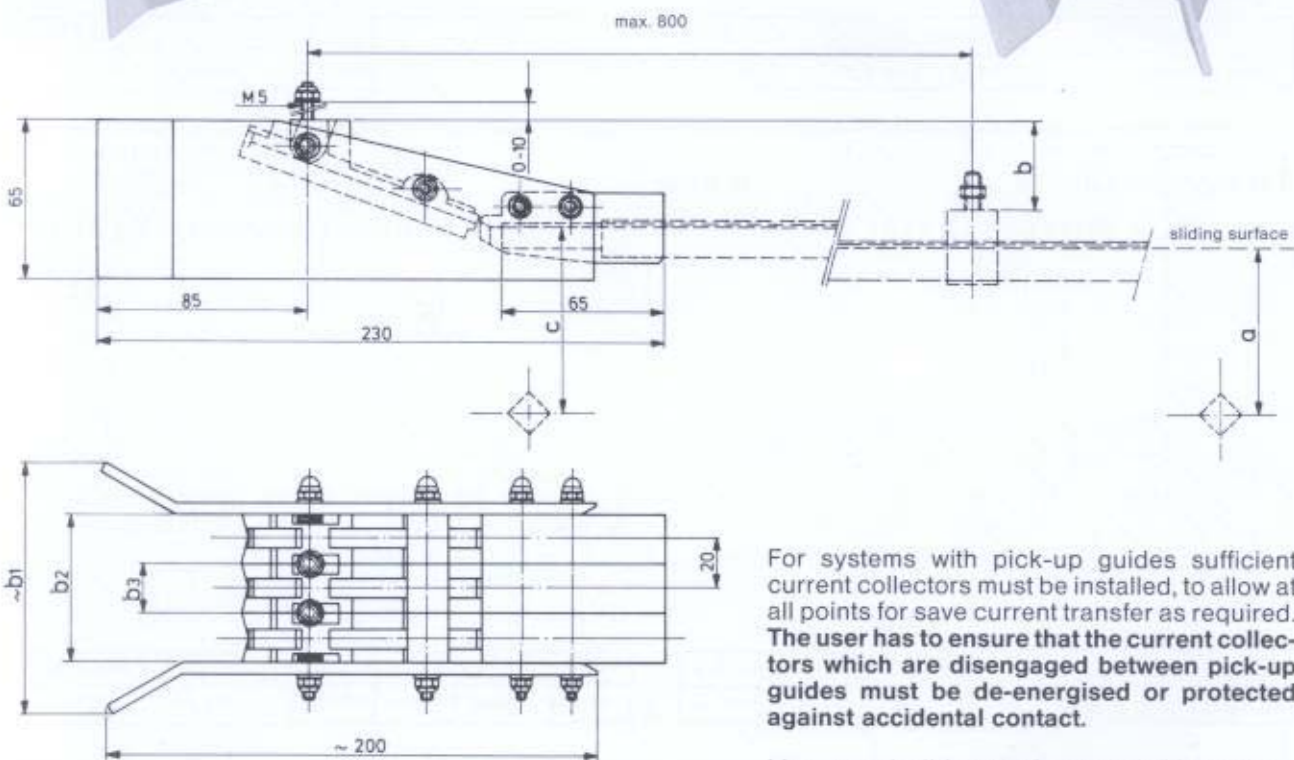
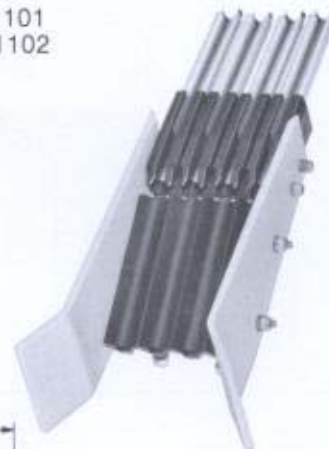

For systems with pick-up guides sufficient current collectors must be installed, to allow at all points for save current transfer as required. **The user has to ensure that the current collectors which are disengaged between pick-up guides must be de-energised or protected against accidental contact.**

Max. permissible transfer speed: 80 m/min.
Higher speeds on request.

Current Collector	a [mm]	b [mm]	c [mm]
Current Collector, short type	50	38	60
Current Collector, long type	75	43	90

The indicated nominal distance 'a' between the centre line of the current collector and the centre line of the conductor rail must be changed by dimension 'b' at the suspension of the pick-up guide so that the clearance dimension 'c' is guaranteed at this point.

Type	Order-no	Number of poles	b1 [mm]	b2 [mm]	b3 [mm]	Weight [kg]
Pick-up Guide 2-pole	081182 - 20 x 2 x 08	2	80	40	-	0,190
Pick-up Guide 3-pole	081182 - 20 x 3 x 08	3	100	60	20	0,280
Pick-up Guide 4-pole	081182 - 20 x 4 x 08	4	120	80	40	0,370
Pick-up Guide 5-pole	081182 - 20 x 5 x 08	5	140	100	60	0,460
Pick-up Guide 6-pole	081182 - 20 x 6 x 08	6	160	120	80	0,550
Pick-up Guide 7-pole	081182 - 20 x 7 x 08	7	180	140	100	0,640
Pick-up Guide 8-pole	081182 - 20 x 8 x 08	8	200	160	120	0,730

Other number of poles on request.

9.2 Pick-up Guide 081182

Long type
only for current collector long type 081102
 for transfer operation.

To compensate for misalignment
 horizontal deflections of ± 30 mm and
 vertical deflections of ± 25 mm

Max. permissible transfer speed:
 80m/min.
 Higher speeds on request.

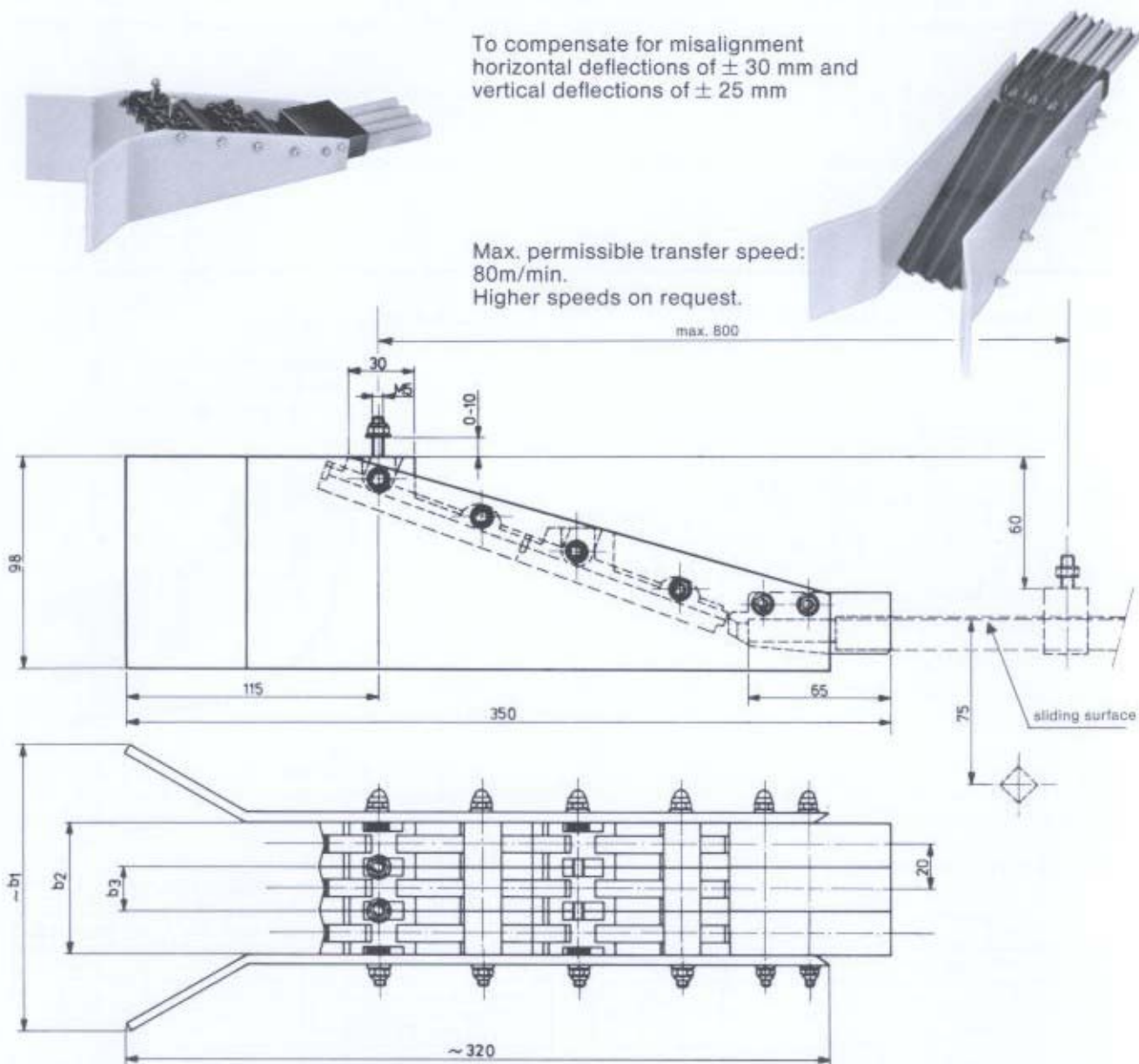

For systems with pick-up guides sufficient current collectors must be installed, to allow at all points for safe current transfer as required.

The user has to ensure that the current collectors which are disengaged between pick-up guides must be de-energised or protected against accidental contact.

Type	Order-no	Number of poles	b1 [mm]	b2 [mm]	b3 [mm]	Weight [kg]
Pick-up Guide 2-pole	081182 - 20 x 2 x 25	2	110	40	-	0,540
Pick-up Guide 3-pole	081182 - 20 x 3 x 25	3	130	60	20	0,600
Pick-up Guide 4-pole	081182 - 20 x 4 x 25	4	150	80	40	0,660
Pick-up Guide 5-pole	081182 - 20 x 5 x 25	5	170	100	60	0,720
Pick-up Guide 6-pole	081182 - 20 x 6 x 25	6	190	120	80	0,780
Pick-up Guide 7-pole	081182 - 20 x 7 x 25	7	210	140	100	0,840
Pick-up Guide 8-pole	081182 - 20 x 8 x 25	8	230	160	120	0,900

Other number of poles on request.

10. CURRENT COLLECTORS (see technical explanation)

Installation hint:

Please note that the centre line of the current collectors corresponds to the centre line of the conductor rail. The distance between towing arm and conductor rail must be set according to the dimension shown (see installation examples).

The connection cables must be highly flexible to guarantee full operational flexibility (see section 10.2 and 10.5) and must be arranged, that no tensional stress is transmitted to the collector head.

For crane installations current collector 081102 should always be used because this collector can accommodate bigger tolerances.

10.1 Current Collector 081101

Short type with 40 mm shoe length
16 Amps and 40 Amps

Visual difference –
the earth collector is
marked yellow and green.

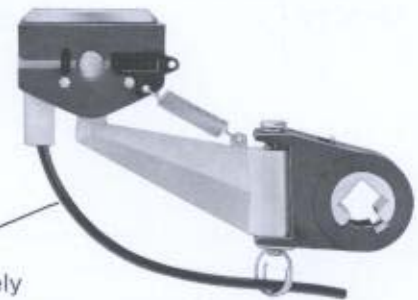
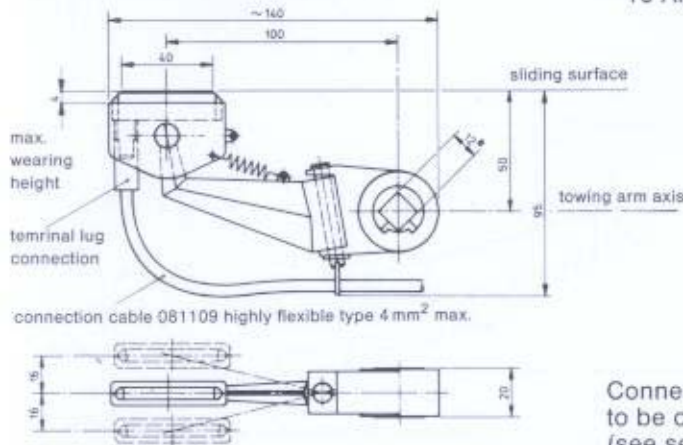

Connection cable
to be ordered separately
(see section 10.2)

Shoe material:
16 Amps – carbon
40 Amps – copper graphite carbon

Contact pressure: 3 N
Movement in direction of contact: ± 20 mm
Lateral movement: ± 16 mm

Standard Current Collector:

Current Collector for transfer operation:
(with distance pieces, see section 10.8)

Type	Order-no	Weight [kg]
Current Collector 40 Amps, phase	081101 – 0011	0,080
Current Collector 40 Amps, earth	081101 – 0012	0,080
Current Collector 16 Amps, phase	081101 – 0031	0,070
Current Collector 16 Amps, earth	081101 – 0032	0,070

Type	Order-no	Weight [kg]
Current Collector 40 Amps, phase	081101 – 3011	0,085
Current Collector 40 Amps, earth	081101 – 3012	0,085
Current Collector 16 Amps, phase	081101 – 3031	0,075
Current Collector 16 Amps, earth	081101 – 3032	0,075

10.2 Connection Cable 081109 for current collectors with 40 mm shoe length

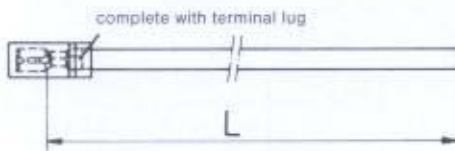

Please note: The connection cable is highly flexible, double insulated and must be ordered in the required length and size. Amperage for single-core cables installed in free air.

Cross-Section [mm ²]	Order-no		Length [m]	Cable diameter [mm]	Amps [A]	Weight [kg/m]
	phase conductor	earth conductor				
1,5	081109 – 1 x 1,5 x 21	081109 – 1 x 1,5 x 42	1	4	25	0,014
2,5	081109 – 1 x 2,5 x 21	081109 – 1 x 2,5 x 42	1	5	34	0,023
4,0	081109 – 1 x 4,0 x 21	081109 – 1 x 4,0 x 42	1	6	45	0,037

Other lengths and sizes on request.

10.3 Current Collector 081101

Short type with 63 mm shoe length
16 Amps and 55 Amps

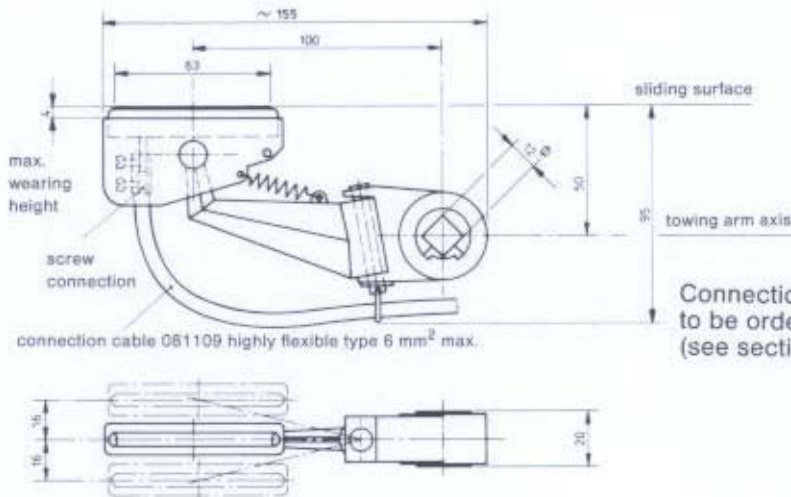

Visual difference – the earth collector is marked yellow and green.



Connection cable to be ordered separately (see section 10.5)

Contact pressure: 7,5 N
Movement in direction of contact: ± 20 mm
Lateral movement: ± 16 mm
Shoe material:
16 Amps – carbon
55 Amps – copper graphite carbon

Standard Current Collector:

Type	Order-no	Weight [kg]
Current Collector 55 Amps, phase	081101 – 0021	0,100
Current Collector 55 Amps, earth	081101 – 0022	0,100
Current Collector 16 Amps, phase	081101 – 0041	0,090
Current Collector 16 Amps, earth	081101 – 0042	0,090

Current Collector for transfer operation:
(with distance pieces, see section 10.8)

Type	Order-no	Weight [kg]
Current Collector 55 Amps, phase	081101 – 3021	0,105
Current Collector 55 Amps, earth	081101 – 3022	0,105
Current Collector 16 Amps, phase	081101 – 3041	0,095
Current Collector 16 Amps, earth	081101 – 3042	0,095

10.4 Current Collector 081102

Long type with 63 mm shoe length
16 Amps and 55 Amps

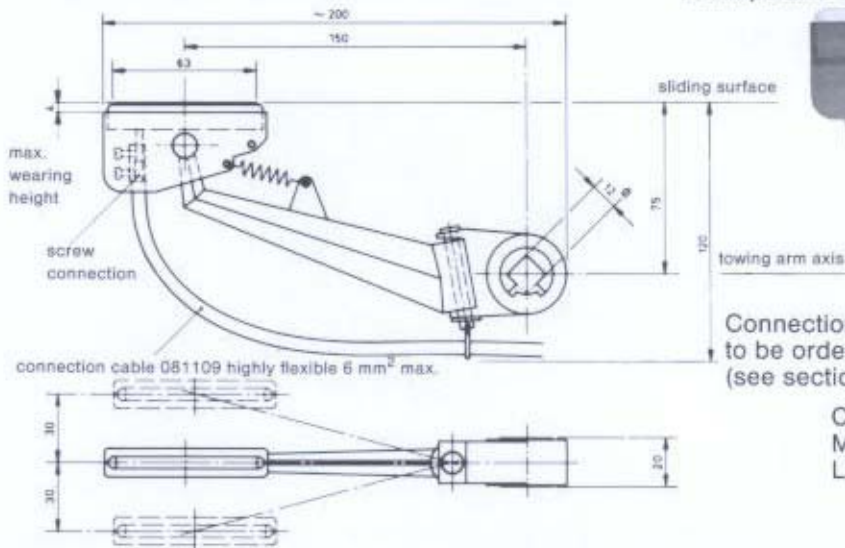

Visual difference – the earth collector is marked yellow and green.

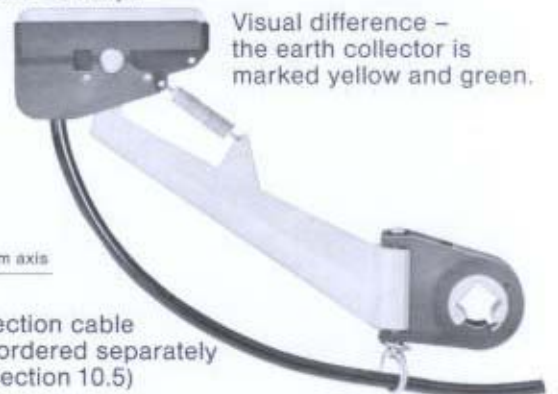

Connection cable to be ordered separately (see section 10.5)

Contact pressure: 5 N
Movement in direction of contact: ± 30 mm
Lateral movement: ± 30 mm
Shoe material:
16 Amps – carbon
55 Amps – copper graphite carbon

Standard Current Collector:

Type	Order-no	Weight [kg]
Current Collector 55 Amps, phase	081102 – 0021	0,140
Current Collector 55 Amps, earth	081102 – 0022	0,140
Current Collector 16 Amps, phase	081102 – 0041	0,130
Current Collector 16 Amps, earth	081102 – 0042	0,130

Current Collector for transfer operation:
(with distance pieces, see section 10.8)

Type	Order-no	Weight [kg]
Current Collector 55 Amps, phase	081102 – 3021	0,145
Current Collector 55 Amps, earth	081102 – 3022	0,145
Current Collector 16 Amps, phase	081102 – 3041	0,135
Current Collector 16 Amps, earth	081102 – 3042	0,135

10.5 Connection Cable 081109 for current collectors with 63 mm shoe length

complete with multicore cable end

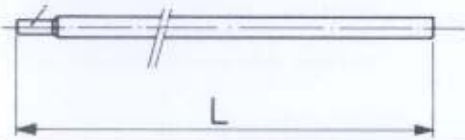

Please note: The connection cable is highly flexible, double insulated and must be ordered in the required length and size. Amperage for single core cables installed in free air.

Cross-Section [mm ²]	Order-no		Length [m]	Cable diameter [mm]	Amps [A]	Weight [kg/m]
	phase conductor	earth conductor				
1,5	081109 - 1 x 1,5 x 11	081109 - 1 x 1,5 x 32	1	4	25	0,014
2,5	081109 - 1 x 2,5 x 11	081109 - 1 x 2,5 x 32	1	5	34	0,023
4,0	081109 - 1 x 4 x 11	081109 - 1 x 4 x 32	1	6	45	0,037
6,0	081109 - 1 x 6 x 11	081109 - 1 x 6 x 32	1	7	57	0,056

Other lengths and sizes on request.

10.6 Towing Arm 020194 for current collectors

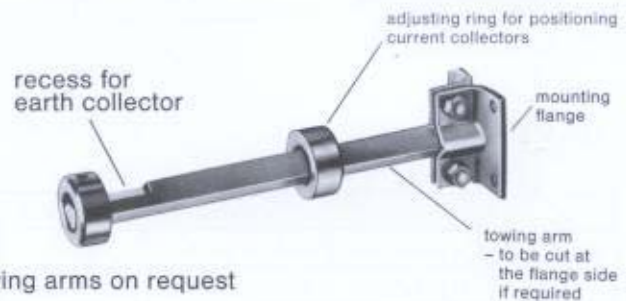
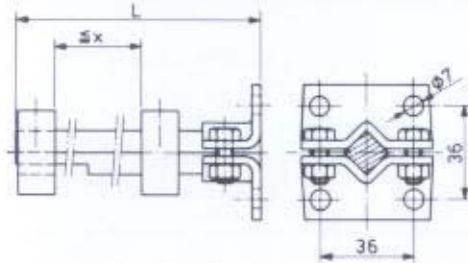

longer towing arms on request

Type	Order-no	L [mm]	x [mm]	Number of poles max.	Weight [kg]
Towing Arm	020194 - 200	200	140	7	0,440
Towing Arm	020194 - 320	320	240	12	0,575
Towing Arm	020194 - 500	500	240	12	0,740

10.7 Collector Support Bracket 081050 for current collectors

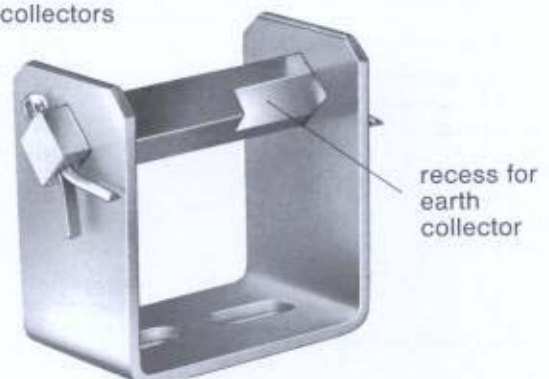
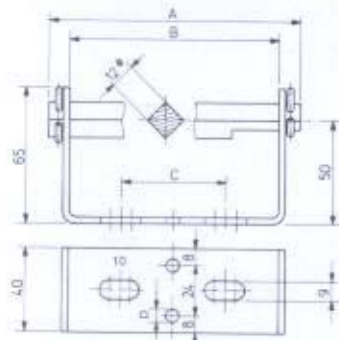

Type	Order-no	Number of poles	A [mm]	B [mm]	C [mm]	D [mm]	Weight [kg]
Collector Support Bracket	081050 - 20 x 2	2	60	40	0	0	0,230
Collector Support Bracket	081050 - 20 x 3	3	80	60	30	5,5	0,300
Collector Support Bracket	081050 - 20 x 4	4	100	80	40	5,5	0,370
Collector Support Bracket	081050 - 20 x 5	5	120	100	50	5,5	0,440
Collector Support Bracket	081050 - 20 x 6	6	140	120	70	5,5	0,510
Collector Support Bracket	081050 - 20 x 7	7	160	140	90	5,5	0,580
Collector Support Bracket	081050 - 20 x 8	8	180	160	110	5,5	0,650
Collector Support Bracket	081050 - 20 x 9	9	200	180	130	5,5	0,720
Collector Support Bracket	081050 - 20 x 10	10	220	200	150	5,5	0,790

Other number of poles on request.

10.8 Distance Pieces for current collectors

Distance pieces are mounted on both sides of the collector head and are used to space the collector heads evenly during transfer operation and measure the carbon wear if a measuring device is installed.

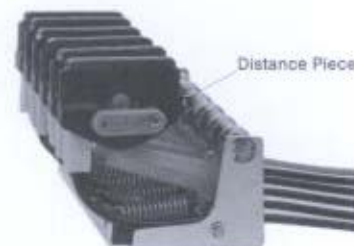
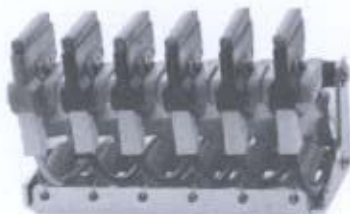

10.9 Current Collector Unit 081106

2 pole for electrical overhead mono rails
16 Amps und 40 Amps, 40 mm shoe length

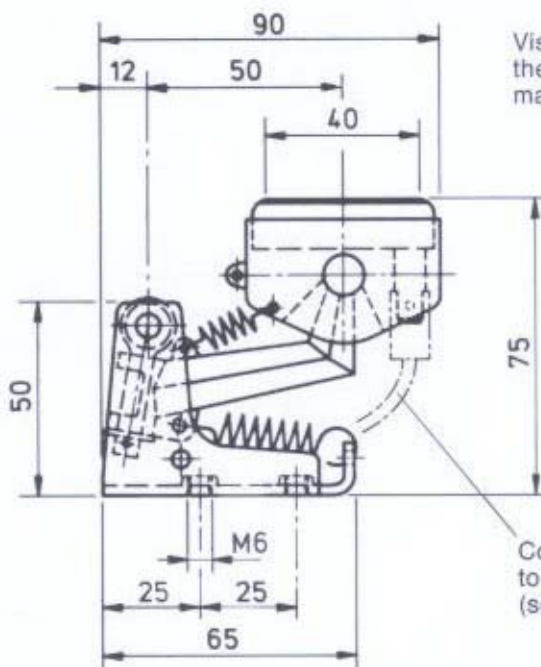
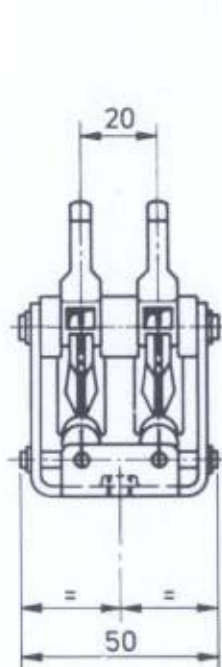

Visual difference – the earth collector is marked yellow and green.

This collector unit is not suitable for operation in systems with pick-up guides!

Connection cable to be ordered separately (see section 10.2)

Shoe material:
16 Amps – carbon
40 Amps – copper graphite carbon

Contact pressure: 6 N
Movement in direction of contact: ± 10 mm
Lateral movement: ± 10 mm

Standard Current Collector Unit:

Type	Amps	Order-no		Weight [kg]
		reversing operation	towing operation	
Current Collector Unit 2-pole	40	081106 – 2001	081106 – 2021	0,230
	16	081106 – 2003	081106 – 2023	0,200

Current Collector Unit with distance pieces:

Type	Amps	Order-no		Weight [kg]
		reversing operation	towing operation	
Current Collector Unit 2-pole	40	081106 – 2301	081106 – 2321	0,240
	16	081106 – 2303	081106 – 2323	0,210

10.10 Current Collector Unit 081106

3-, 4-, 5-, 6-pole for electrical overhead mono rails
16 Amps and 40 Amps, 40 mm shoe length

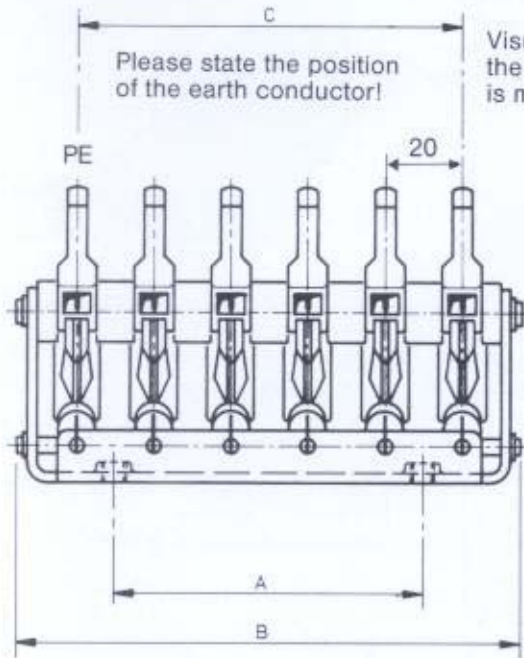

Visual difference – the earth collector is marked yellow and green.

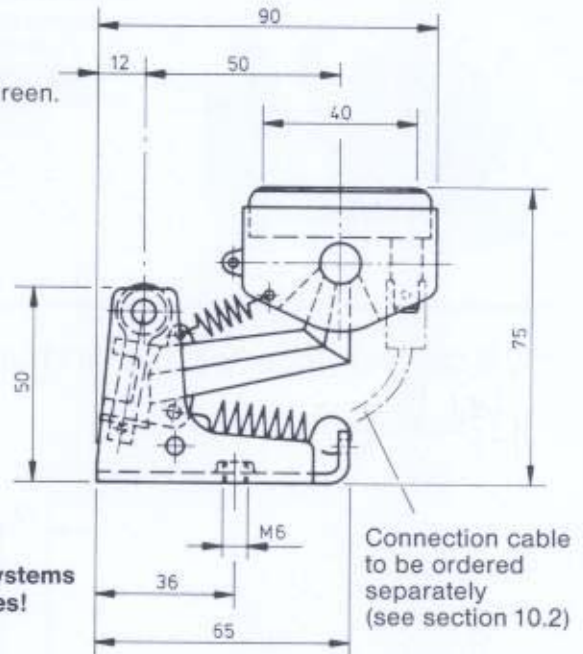

This collector unit is not suitable for operation in systems with pick-up guides!

Shoe material:
16 Amps – carbon
40 Amps – copper graphite carbon

Number of poles	,A' [mm]	,B' [mm]	,C' [mm]
3	20	71	40
4	40	91	60
5	60	111	80
6	80	131	100

Contact pressure: 6 N
Movement in direction of contact: ± 10 mm
Lateral movement: ± 10 mm

Standard Current Collector Unit:

Type	Amps	Order-no		Weight [kg]
		reversing operation	towing operation	
Current Collector Unit 3-pole	40	081106 – 3001	081106 – 3021	0,305
	16	081106 – 3003	081106 – 3023	0,260
Current Collector Unit 4-pole	40	081106 – 4001	081106 – 4021	0,380
	16	081106 – 4003	081106 – 4023	0,320
Current Collector Unit 5-pole	40	081106 – 5001	081106 – 5021	0,455
	16	081106 – 5003	081106 – 5023	0,380
Current Collector Unit 6-pole	40	081106 – 6001	081106 – 6021	0,530
	16	081106 – 6003	081106 – 6023	0,440

Current Collector Unit with distance pieces:

Type	Amps	Order-no		Weight [kg]
		reversing operation	towing operation	
Current Collector Unit 3-pole	40	081106 – 3301	081106 – 3321	0,320
	16	081106 – 3303	081106 – 3323	0,275
Current Collector Unit 4-pole	40	081106 – 4301	081106 – 4321	0,400
	16	081106 – 4303	081106 – 4323	0,340
Current Collector Unit 5-pole	40	081106 – 5301	081106 – 5321	0,480
	16	081106 – 5303	081106 – 5323	0,405
Current Collector Unit 6-pole	40	081106 – 6301	081106 – 6321	0,560
	16	081106 – 6303	081106 – 6323	0,470

10.11 Current Collector Unit 081106

3-, 4-, 5-, 6-pole for electrical overhead mono rails
16 Amps and 55 Amps, 63 mm shoe length

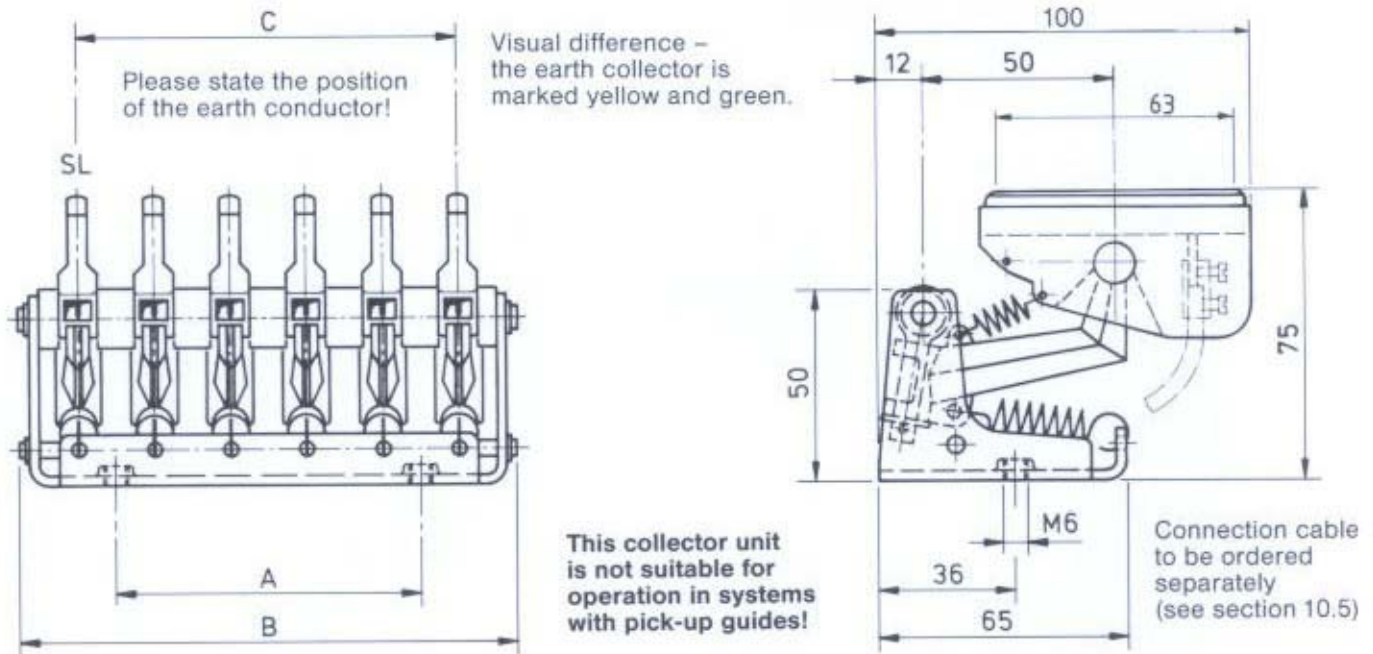

Shoe material:
16 Amps – carbon
55 Amps – copper graphite carbon

Number of poles	,A' [mm]	,B' [mm]	,C' [mm]
5	60	111	80
6	80	131	100

Contact pressure: 6 N
Movement in direction of contact: ± 10 mm
Lateral movement: ± 10 mm

Standard Current Collector Unit:

Type	Amps	Order-no		Weight [kg]
		reversing operation	towing operation	
Current Collector Unit 5-pole	55	081106 – 5002	081106 – 5022	0,530
	16	081106 – 5004	081106 – 5024	0,480
Current Collector Unit 6-pole	55	081106 – 6002	081106 – 6022	0,630
	16	081106 – 6004	081106 – 6024	0,570

Current Collector Unit distance pieces:

Type	Amps	Order-no		Weight [kg]
		reversing operation	towing operation	
Current Collector Unit 5-pole	55	081106 – 5302	081106 – 5322	0,555
	16	081106 – 5304	081106 – 5324	0,505
Current Collector Unit 6-pole	55	081106 – 6302	081106 – 6322	0,660
	16	081106 – 6304	081106 – 6324	0,600

11. SPARE PARTS (see technical explanation)

Installation hint:

The collector shoes are replaced as follows:

1. Remove the stabilizing spring of the old current collector head (no overstretching!).
2. Disconnect the connection cable.
3. Pull the collector head over the lock point.
4. Mount the new collector head in reverse order.

11.1 Collector Shoe 081002 (spare part) 40 mm carbon length (terminal lug connection)

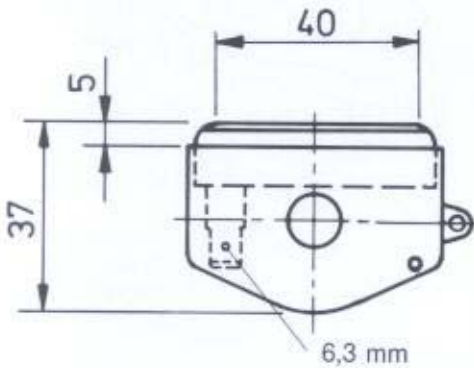

Type		Order-no	Weight [kg]
Collector shoe short type	16 Amps phase	081002 - 1 x 1	0,010
	16 Amps earth	081002 - 2 x 1	0,010
	40 Amps phase	081002 - 1 x 2	0,025
	40 Amps earth	081002 - 2 x 2	0,025

Note:

For use in installations with transfers please order 1 set distance pieces with screws 08 - D002 - 0566 per collector shoe.

11.2 Collector Shoe 081002 (spare part) 63 mm carbon length (screw connection)

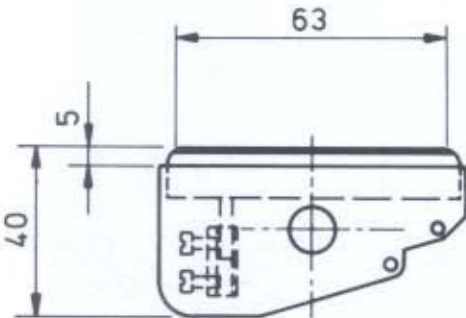

Type		Order-no	Weight [kg]
Collector shoe long type	16 Amps phase	081002 - 1 x 3	0,020
	16 Amps earth	081002 - 2 x 3	0,020
	55 Amps phase	081002 - 1 x 4	0,035
	55 Amps earth	081002 - 2 x 4	0,035
	data	081002 - 1 x 9	0,035

Note:

For use in installations with transfers please order 1 set distance pieces with screws 08 - D002 - 0566 per collector shoe.

11.3 Stabilizing Spring for current collector head

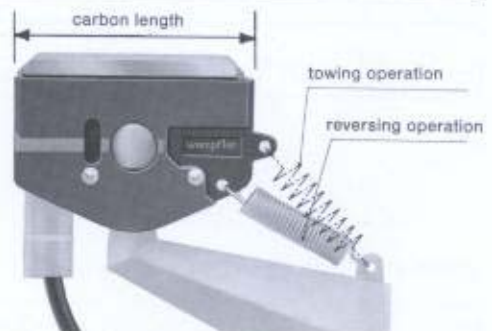
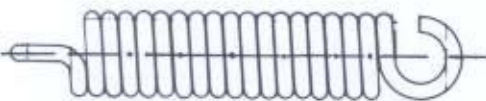

Type	for current collector	carbon length [mm]	Order-no
Stabilizing Spring	081101/081102	40/63	RZ - 056 I
	081106	40	RZ - 024 AE I
	081106	63	RZ - 040

12. ACCESSORIES (see technical explanation)

12.1 Insulated spade terminal 6,3 x 0,8 (blue) for 1,5 mm² up to 2,5 mm²

For use in power feeds with spade terminal connection

Type	Order-no
Insulated terminal lug 1,5 . . . 2,5 mm ²	08 - 9 - 160313 - 2



12.2 Insulated spade terminal 6,3 x 0,8 (yellow) for 4,0 mm² up to 6,0 mm²

For use in power feeds with spade terminal connection

Type	Order-no
Insulated terminal lug 4,0 . . . 6,0 mm ²	08 - 160314 - 2



12.3 Terminal lug (blue) for 1,5 mm² up to 2,5 mm²

For use in power feed clamp 081153E

Type	Order-no
Terminal lug 1,5 . . . 2,5 mm ²	0074301



12.4 Uninsulated terminal lug for 1,5 mm² to 2,5 mm²

Terminal lug connection for current collector head with 40 mm shoe length

Type	Order-no
Uninsulated terminal lug 1,5 . . . 2,5 mm ²	08 - 160256 - 2



12.5 Uninsulated terminal lug for 2,5 mm² up to 4,0 mm²

Terminal lug connection for current collector head with 40 mm shoe length

Type	Order-no
Uninsulated terminal lug 2,5 . . . 4,0 mm ²	45047 123.211



12.6 Insulation shroud \varnothing 6 mm max.

For use with current collector head with 40 mm shoe length

Type	Order-no
Insulation shroud \varnothing 6 mm max.	08 - 925068 - 0

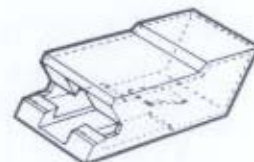

12.7 Multicore cable end for 1,5 mm² . . . 2,5 . . . 4 and 6 mm²

For use in power feed clamp 081153E and for current collector head with 63 mm shoe length

Type	Order-no
Multicore Cable End 1,5 mm ²	08 - 73/7
Multicore Cable End 2,5 mm ²	08 - 74/9
Multicore Cable End 4 mm ² and 6 mm ²	08 - 75/10



13. TOOLS (see technical explanation)

13.1 Bending Device 081081

The three-roller bending device curves conductor rails with insulation cover in all four planes. By setting the adjusting screw any curve with a bending radius of 500 mm up to ∞ in the vertical plane and 1500 mm up to ∞ in the horizontal plane can be bent on site.

If a smaller bending radius is required please consult factory.

To avoid deformation of the rail the enclosed plastic insert must be pushed into the rail before lateral bending and must be removed after the bending procedure.

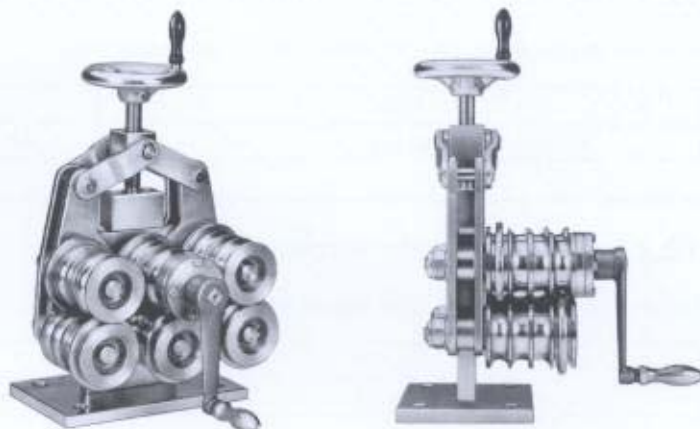

Type	Order-no	Weight [kg]
Bending Device	081081	15,800

The plastic insert for lateral bending is enclosed with the consignment.

13.2 Notching Pliers 081082

If conductor rails are cut off for isolating joints or fitting pieces etc. notches must be remade at the rail ends. The notches can be made in the factory as well as on site by adjusting the set wheel of the notching pliers to the respective position.

Position 'V': notches for rail connector
Position 'B': notches for isolating joints
Position 'D': notches for expansion joints

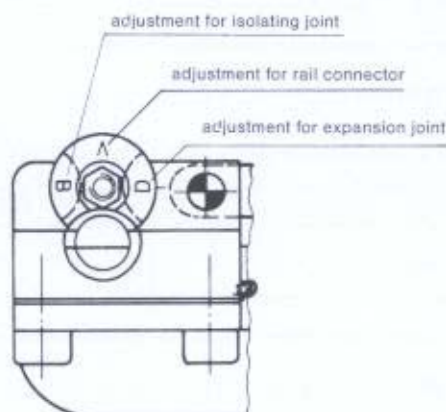

Type	Order-no	Weight [kg]
Notching Pliers	081082	1,460

13.3 Cutting Pliers 081086

With this tool the conductor rails can be easily cut to any length. Deburring is not necessary because the conductor rails are cut so that the contact side has a chamfered edge.

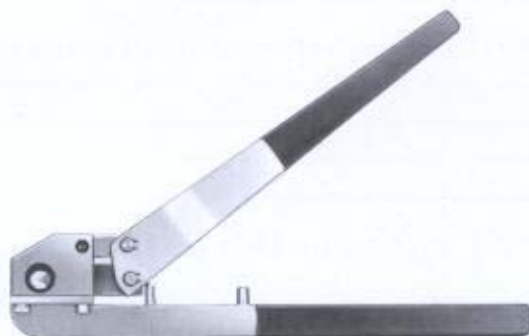

Type	Order-no	Weight [kg]
Cutting Pliers	081086	1,500

13.4 Insulation Punching Tool 081084

This device is used to punch a hole into the insulation cover. Through this hole a cable is clamped to the conductor rail with the power feed clamp 081153 E and the flat terminal tongue. By means of this device holes can be punched at any point on the insulation cover.



Type	Order-no	Weight [kg]
Insulation Punching Tool	081084	0,400

13.5 Rail Calibration Tool 081083

For calibration of deformed rails:

- ① the rail end is deformed to a smaller diameter
- ② the rail end is deformed to a bigger diameter
- ③ the rail end is twisted along the slot

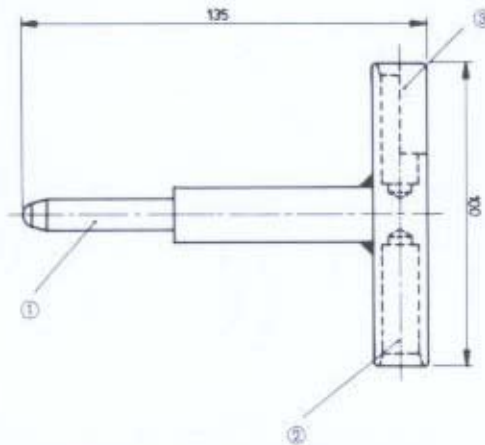

Type	Order-no	Weight [kg]
Rail Calibration Tool	081083	0,290

13.6 Release Pliers 081085

For dismantling the conductor rails the hanger clamps are spread by the pliers so that the conductor rails can be easily removed.

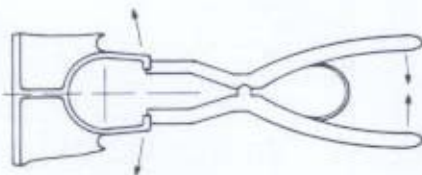

Pliers in use



Type	Order-no	Weight [kg]
Release Pliers	081085	0,160

CURVES

HANGER CLAMP ARRANGEMENT FOR CURVED INSTALLATIONS

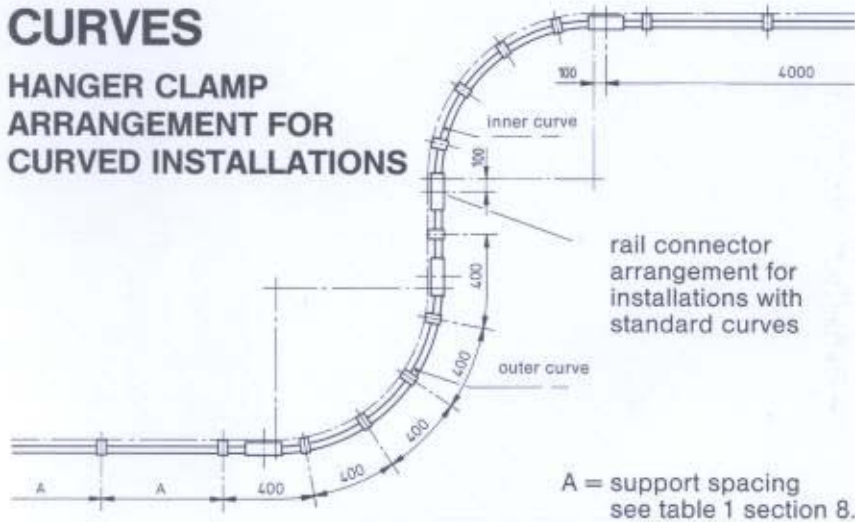

vertical conductor rail arrangement

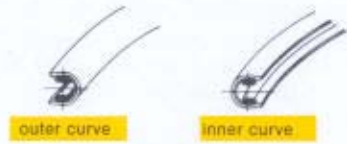

horizontal conductor rail arrangement



A = support spacing
see table 1 section 8.5

STANDARD CURVES 811

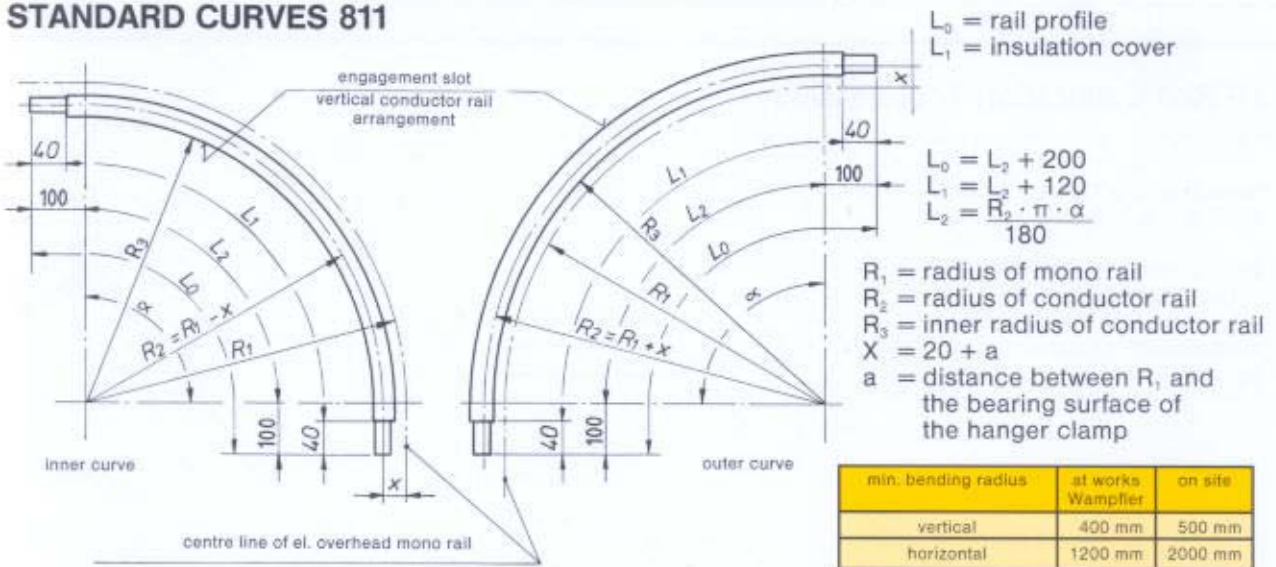

ORDER NUMBER CODE FOR STANDARD CURVES

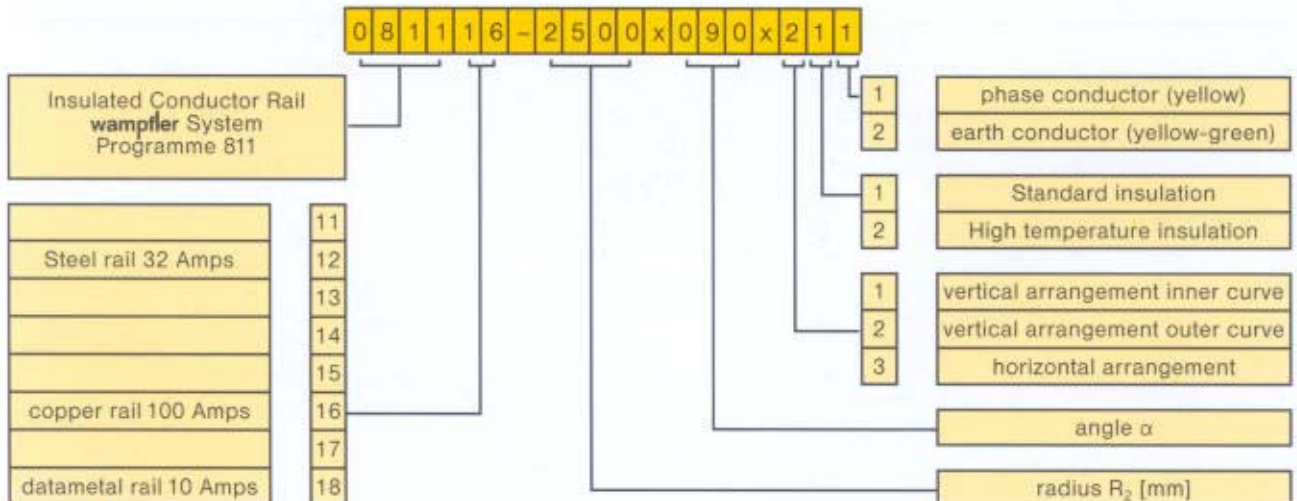

Example: Insulated Conductor Rail, Programme 811; $R_2 = 2500$ mm; $\alpha = 90^\circ$; vertical arrangement (outer curve); standard insulation; phase conductor, copper rail 100 Amps.
Order-no: 081116 - 2500 x 090 x 211

QUESTIONNAIRE

for determining the wampfler-conductor rail system

Programme 811

1. **Type of consumer:**
Hoist, mono-rail, crane etc. _____
2. **Length of conductor rail system:** _____
3. **Conductor rail arrangement:** _____
vertical horizontal
For special applications please enclose a sketch and description.
4. **Number of conductor rail system:** _____
5. **Number of conductor rail poles:**
Phase conductor rail _____
Earth conductor rail _____
Control conductor rail _____
Data conductor rail _____
6. **Length of collector connecting cable:** _____ m
7. **Operating voltage:**
3 phase current _____ V _____ Hz
Alternating current _____ V _____ Hz
Direct current _____ V
8. **Working current and voltage:**
Phase conductor rail _____ V _____ Amps _____ % Duty Cycle
Control conductor rail _____ V _____ Amps _____ % Duty Cycle
Data conductor rail _____ V _____ Amps _____ % Duty Cycle
9. **Number of consumers per system:** _____
10. **Current consumption per consumer:** _____ Amps
11. **Max. travelling speed:** _____ m/min
12. **Max. permissible voltage drop:** _____ V
13. **Power feed per conductor rail:**

	number	end feed	center feed
Phase conductor rail	_____	<input type="checkbox"/>	<input type="checkbox"/>
Earth conductor rail	_____	<input type="checkbox"/>	<input type="checkbox"/>
Control conductor rail	_____	<input type="checkbox"/>	<input type="checkbox"/>
Data conductor rail	_____	<input type="checkbox"/>	<input type="checkbox"/>

14. Separation sections on phase conductors: yes no _____ per phase conductor
 isolating piece _____ air gap
15. Separation sections on control conductors: yes no _____ per control conductor
 isolating piece _____ air gap
16. Special installations: switches _____ lift stations _____ transfer points _____
17. Displacement of runway: height \pm _____ mm max. lateral \pm _____ mm max.
air gap \pm _____ mm max.
18. Mounting of conductor rail:
type of hanger clamp _____
mounting height above working floor level _____ m
19. Curves: yes no
min. bending radius _____ mm
max. bending radius _____ mm
 vertical arrangement: inner curve
outer curve
 horizontal arrangement
20. Indoor installation Outdoor installation
21. Operating conditions: _____
(dampness, dust, aggressive gases etc.)
22. Ambient temperature: max. _____ °C, min. _____ °C

Further information for determining: _____

Please attach a copy of this questionnaire to your inquiry!

SYSTEM ARRANGEMENT

PROGRAMME 811

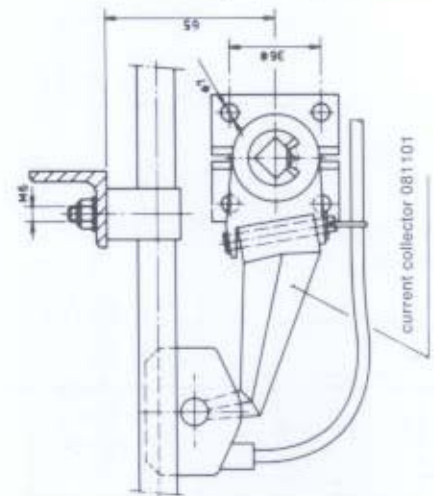
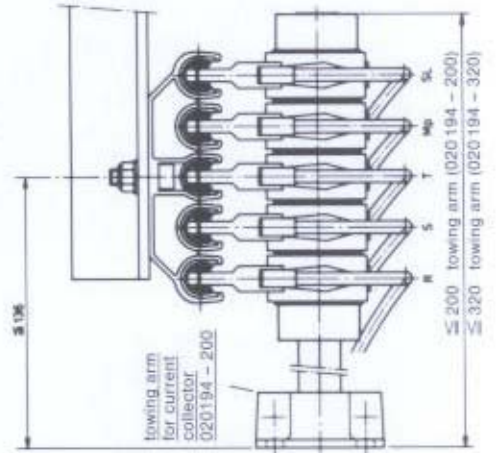
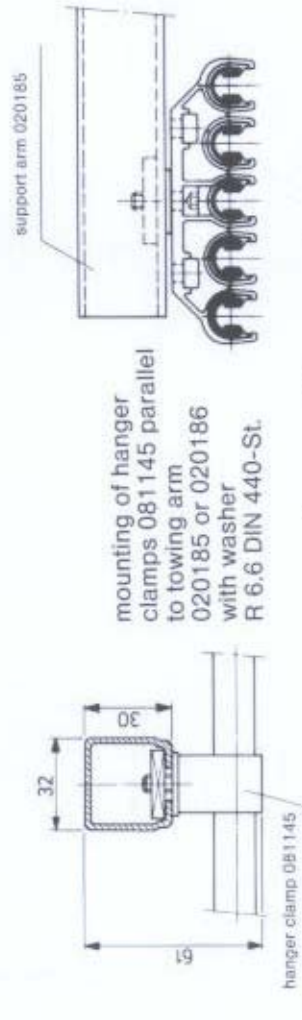
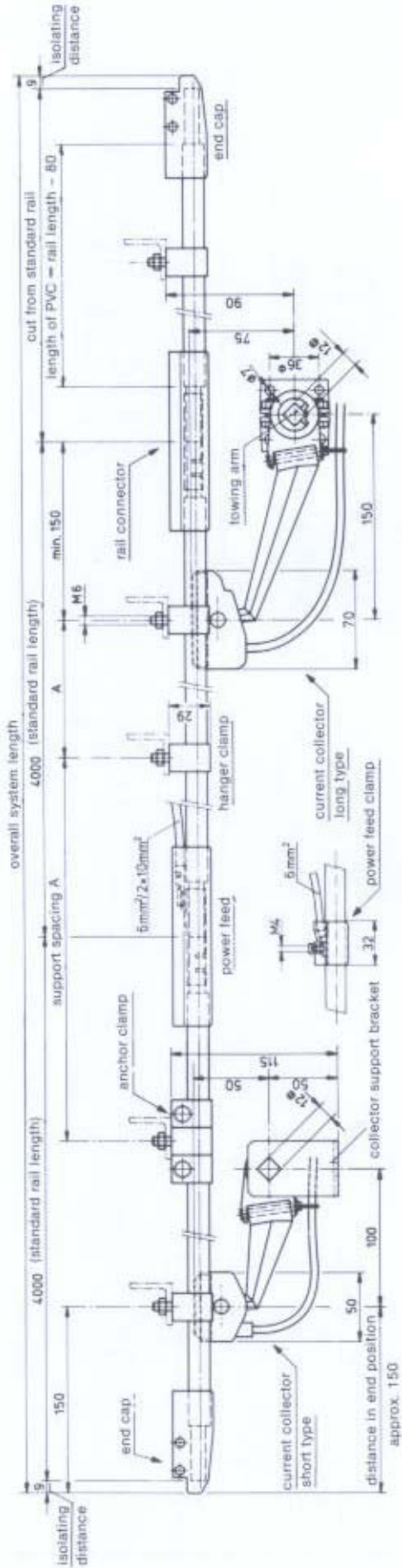

SLIP RING ASSEMBLY

PROGRAMME 811

with any number of poles and variable diameter
made from standard parts of conductor rail system programme 811

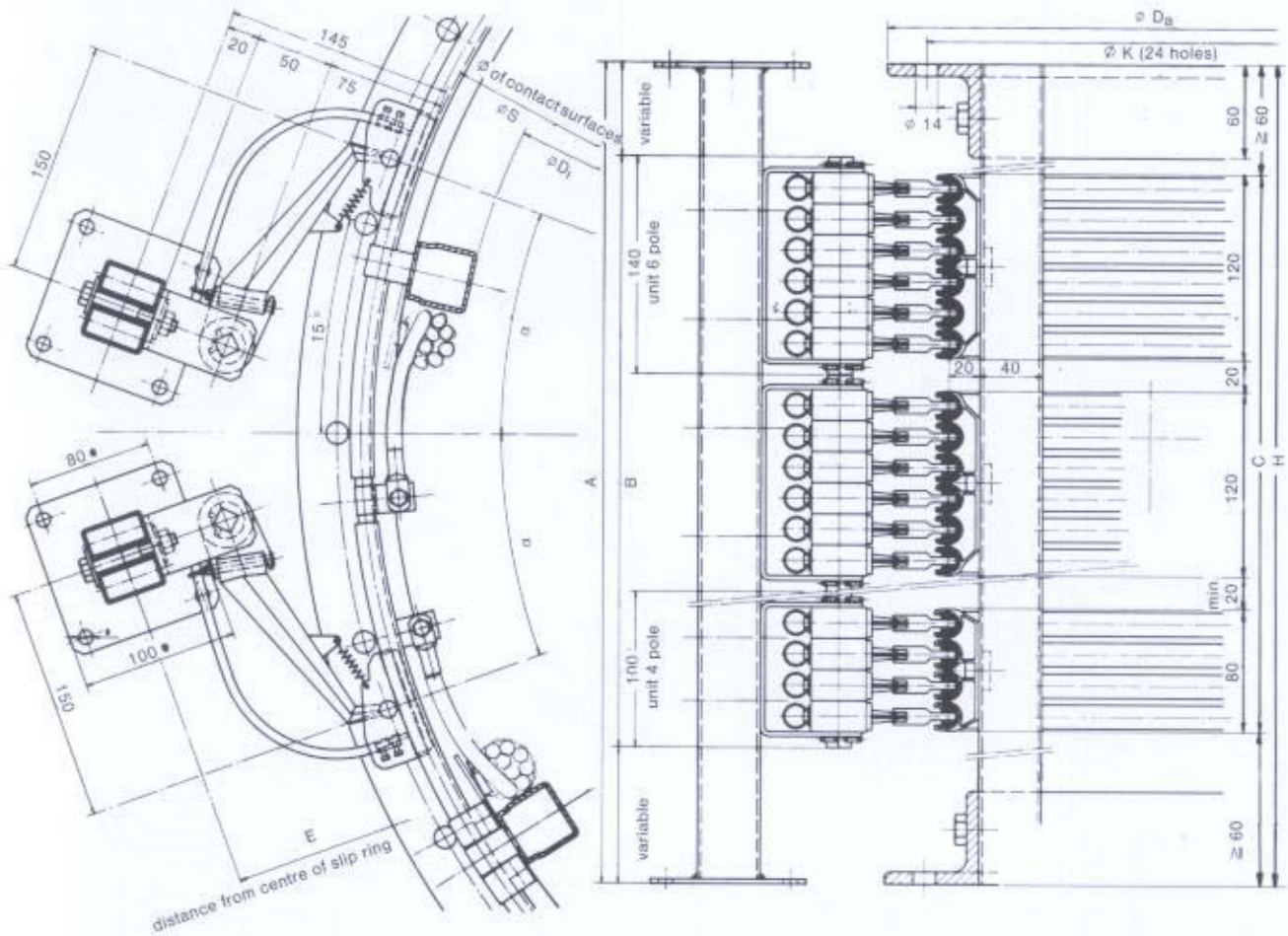

The installation dimensions can be calculated by means of the table below.

Dimension	Function	min. [mm]	max. [mm]
A	Installation dimension	120	4000
B	$B \approx \text{number of poles} \times 23 \frac{1}{2}$	100	3900
C	$C = B - 20$	80	3880
H	Installation dimension	200	4000
$\varnothing S$	\varnothing nominal	500	-
$\varnothing D_a$	$D_a = S + 90$	590	-
$\varnothing K$	$K = S + 40$	540	-
$\varnothing D_i$	$D_i = S - 110$	390	-
E	$E = \frac{S}{2} + 145$	395	-
$\sphericalangle d$	$\sin \alpha \approx \frac{360}{S}$	-	-



Wampfler AG • Rheinstrasse 27+33 • D-79576 Weil am Rhein-Maerkt
Customer Support: Phone +49 (0) 7621 / 66 22 22 • Fax +49 (0) 7621 6 62-144
E-Mail: info@wampfler.com • <http://www.wampfler.com>